

AV7000 12K



Redefining Logistics Leadership in Ultra-High Definition



Introducing the AV7000 12K, the next-generation 12,000-pixel wide linear imager that is redefining standards in the T&L market. This advanced solution is designed to deliver exceptional optical performance, enhanced Auto-ID capabilities, and powerful software tools for image processing, data storage, operational analysis, and process optimization.

Equipped with a state-of-the-art 12K CMOS sensor and exclusive Datalogic patented technologies, the AV7000 12K delivers high-definition images and software functionalities that surpass customer expectations. The AV7000 12K is the ideal choice for applications with very high density barcodes, down to 6mil, and for wide belt transports and cross belt sorters.

With its wide field of view, the AV7000 12K captures detailed, high-definition images in a single shot across conveyors up to 1600 mm wide—eliminating the need for multiple partial images.

Thanks to Datalogic's patented Pulsed Lighting System, the multi-sided AV7000 12K reading station now occupies 50% less space than traditional non-pulsed lighting systems, making it the perfect choice for space-constrained applications.

The AV7000 12K excels in demanding image processing applications due to the very high DPI images it can capture with the 12000 wide pixel and multiple lens options, including HazMat identification, OCR, package analytics, cross-belt inspection, and label-sensitive text blurring. It ensures secure communication and supports multiple formats, providing reliable solutions for critical tasks.

Designed for the most demanding parcel sorting applications, the AV7000 12K is the ideal choice for Express Courier services and Retail Distribution companies, offering high-definition imaging and unmatched performance.



PLS

Pulsed Lighting System



12K@40kHz

High performance 12K linear Imager



D-Zoom

Digital Zoom



HD

Single shot high definition image



AF-2G

High speed auto-focus system



Stop-N-Go

Stop-N-Go reading capabilities



VL-5G

Enhanced decoding library



e-GENIUS

Web browser configuration tool



Linux OS

LINUX Operating System

HIGHLIGHTS

- High line rate, 12K wide linear imager sensor
- Single view high quality picture for very large conveyors up to 1600mm
- Patented Autofocus System offering extended DoF
- Patented PLS technology, reducing the footprint of the reading station by 50%
- Patented Digital Zoom technology assuring constant DPI resolution
- Enhanced decode algorithm for challenging 1D and 2D bar codes
- Multiple format image saving from full definition to highly compressed JPG
- Browser based interface, compatible with any kind of OS and HW platform including PC and Tablet
- Secure communications
- Operating system easily updated to comply with global SW security requirements
- Redundant architecture with no single point of failure
- Software tools for image saving and data intelligence.
- Linux operating system

TARGET MARKETS AND APPLICATIONS

- High speed Parcel sortation
- Cross belt sorters
- High density barcodes
- Dimension Weigh Scan System
- OCR, Hazmat, and package identification
- Extended ID and image saving
- Redundant architecture (double controller, tachometer, photo-eye and closed EBC loop)

MODELS AND ACCESSORIES

Field of View	up to 1600 mm (63 in)
Max Resolution	Up to 320 pixels/inch (DPI) *
Scan Rate	Up to 40,000/s (40kHz)
Imager Sensor Features	High Speed CMOS Line Scan (12288 pixels)
Optical lens	80 mm, 100 mm and 120 mm *
Aperture Angle	15° to 45° *
Readable Barcodes	All Standard 1D and 2D Symbologies
IP Rating	IP65
Dimensions (Typical Value)	with external fans and Short Illumination: 845x416x237 mm [33.3x16.4x9.3 in] with external fans and Medium Illumination: 1150x416x237 mm [45.3x16.4x9.3 in] with external fans and long Illumination: 1480x416x237 mm [58.3x16.4x9.3 in]
Weight	11 kg [24 lbs]
Temperature Range	Operating: 0° to 50° C [32° to 122° F] Storage: -20° to 70° C [-4° to 158° F]
Power Supply/Consumption	23-26VDC at illuminator connector
Case Material	Aluminum die-cast
Ethernet	1 Gigabit Ethernet for decoding data to Host (may also be used for setup) 1 Gigabit Ethernet for image file transfer to Host
Serial Ports	1 Main (COM) RS232/RS485FD opto-isolated serial port up to 115.2 Kbit/s 1 Aux RS232 opto-isolated serial port up to 115.2 Kbit/s
Internal Communication System	SyncNet Technology
Digital Inputs	3 x Inputs (2 + 1 x "Encoder"), optocoupled, NPN/PNP
Digital Outputs	2 x Outputs SW programmable, optocoupled, event driven, NPN

* Depends on model and/or application type

MECHANICAL DRAWINGS

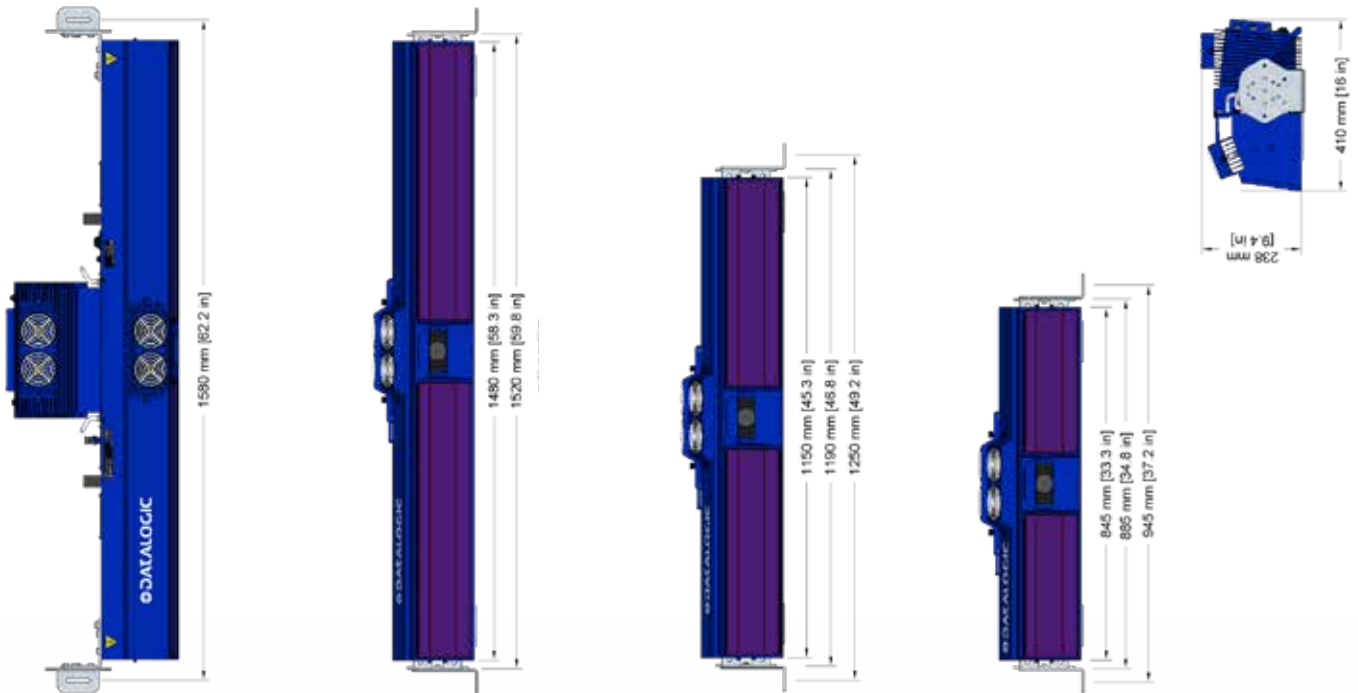

MODELS

MODEL	DESCRIPTION	PART NUMBER
	AV7000 12K Reader	
AV7000-2000	AV7000 12k linear camera with 120mm f/5.6 lens	934002000
AV7000-2100	AV7000 12k linear camera with 100mm f/5.6 lens	934002100
AV7000-2200	AV7000 12k linear camera with 80mm f/8 lens	934002200
	AI7000 Illumination	
AI7000-1100	MEDIUM LIGHTING SYS	934001110
AI7000-1500	LONG LIGHTING SYS	934001120

Rev. 01, 02/2025



The company endeavours to continuously improve and renew its products; for this reason the technical data and contents of this catalogue may undergo variations without prior notice. For correct installation and use, the company can guarantee only the data indicated in the instruction manual supplied with the products. Product and Company names and logos referenced may be either trademarks or registered trademarks of their respective companies. We reserve the right to make modifications and improvements.