

# MATRIX 220™

## QUICK REFERENCE GUIDE



## Image Based Industrial Reader

©2018-2026 Datalogic S.p.A. and/or its affiliates

All rights reserved. Without limiting the rights under copyright, no part of this documentation may be reproduced, stored in or introduced into a retrieval system, or transmitted in any form or by any means, or for any purpose, without the express written permission of Datalogic S.p.A. and/or its affiliates.

Owners of Datalogic products are hereby granted a non-exclusive, revocable license to reproduce and transmit this documentation for the purchaser's own internal business purposes. Purchaser shall not remove or alter any proprietary notices, including copyright notices, contained in this documentation and shall ensure that all notices appear on any reproductions of the documentation.

Electronic versions of this document may be downloaded from the Datalogic website ([www.datalogic.com](http://www.datalogic.com)). If you visit our website and would like to make comments or suggestions about this or other Datalogic publications, please let us know via the "Contact" page.

### Disclaimer

Datalogic has taken reasonable measures to provide information in this manual that is complete and accurate, however, Datalogic shall not be liable for technical or editorial errors or omissions contained herein, nor for incidental or consequential damages resulting from the use of this material. Datalogic reserves the right to change any specification at any time without prior notice.

### Trademarks

Datalogic and the Datalogic logo are registered trademarks of Datalogic S.p.A. in many countries, including the U.S.A. and the E.U.

Matrix, ID-NET, DL.CODE, and X-PRESS are trademarks of Datalogic S.p.A. and/or its affiliates. All other brand and product names may be trademarks of their respective owners.

### Datalogic S.r.l.

Via San Vitalino 13  
40012 Calderara di Reno (BO)  
Italy  
Tel. +39 051 3147011  
Fax +39 051 3147205

[www.datalogic.com](http://www.datalogic.com)



821012941 (Rev. B) March 2026



**NOTE:** This Quick Reference Guide does not replace the Product Reference Guide. Download the Product Reference Guide by reading the QR code here or at [www.datalogic.com](http://www.datalogic.com).



**NOTE:** Scan this QR code to download the multilingual quick guide.

**NOTA:** Scansionare questo QR Code per scaricare la guida rapida multilingue.

**HINWEIS:** Scannen Sie diesen QR-Code, um die mehrsprachige Kurzanleitung herunterzuladen.

**NOTA:** Escanee este código QR para descargar la guía rápida multilingüe.



**REMARQUE:** Scannez le code QR suivant pour télécharger le guide rapide multilingue.

**OPMERKING:** Scan deze QR-code om de meertalige snelgids te downloaden.

**ANMÄRKNING:** Skanna denna QR-kod för att ladda ner den flerspråkiga snabbguiden.

注释: 扫描此二维码下载多语种快速指南。

## INSTALLATION PROCEDURE

1. Physically mount the Matrix 220 reader.
2. Make the necessary electrical connections.
3. Configure the reader using the X-PRESS interface (AIM MODE, AUTOMATIC SETUP and TEST for simple configuration) or the DL.CODE software configuration program (complete configuration).

## HMI X-PRESS™ INTERFACE

In normal operating mode the colors and meaning of the five LEDs are illustrated in the following table:

READY (green)	indicates the device is ready to operate.
GOOD (green)	confirms successful reading.
TRIGGER (yellow)	indicates the status of the reading phase.
COM (yellow)	indicates active communication on main serial port.
STATUS (red)	indicates a NO READ result.

During the reader startup (reset or restart phase), all the LEDs blink for one second.



HMI X-PRESS™

The single push button gives immediate access to the following relevant functions:

	Test Mode with bar graph visualization to check static reading performance.
	Aim Mode turns on the LED pointers to aim the reader at the target. <b>The target should be centered horizontally and vertically with respect to the aiming squares.</b>
	Automatic Setup to self-optimize and auto-configure photometry parameters.

## PRODUCT OVERVIEW

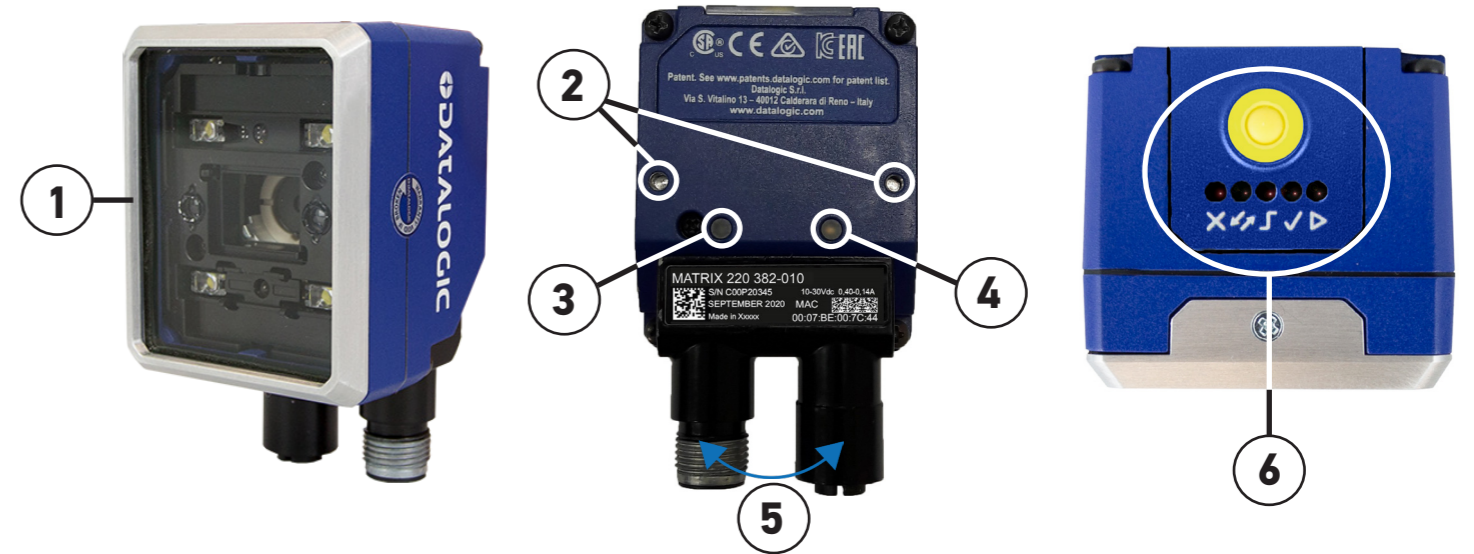

1	Reading Window (ESD model shown)
2	Bracket Mounting Holes (2)
3	Power On LED

4	Ethernet Connection LED
5	90° Rotating Connector Block
6	HMI X-PRESS™ Interface

Matrix 220 3xx-x4x

Matrix 220 3xx-x1x

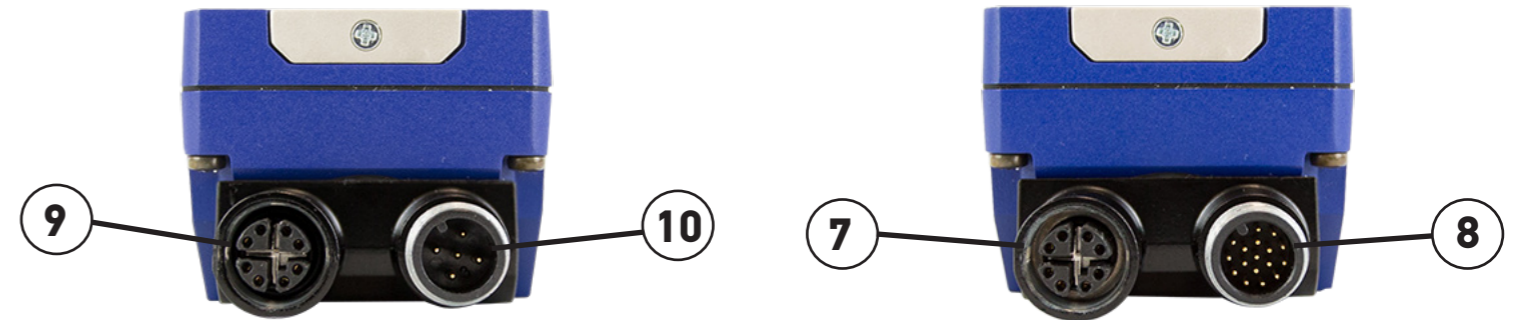

9	Power Over Ethernet Connector
10	COM, trigger Connector

7	Ethernet Connector
8	Power - COM - I/O Connector

Matrix 220 DPM Models

Matrix 220 Standard Models

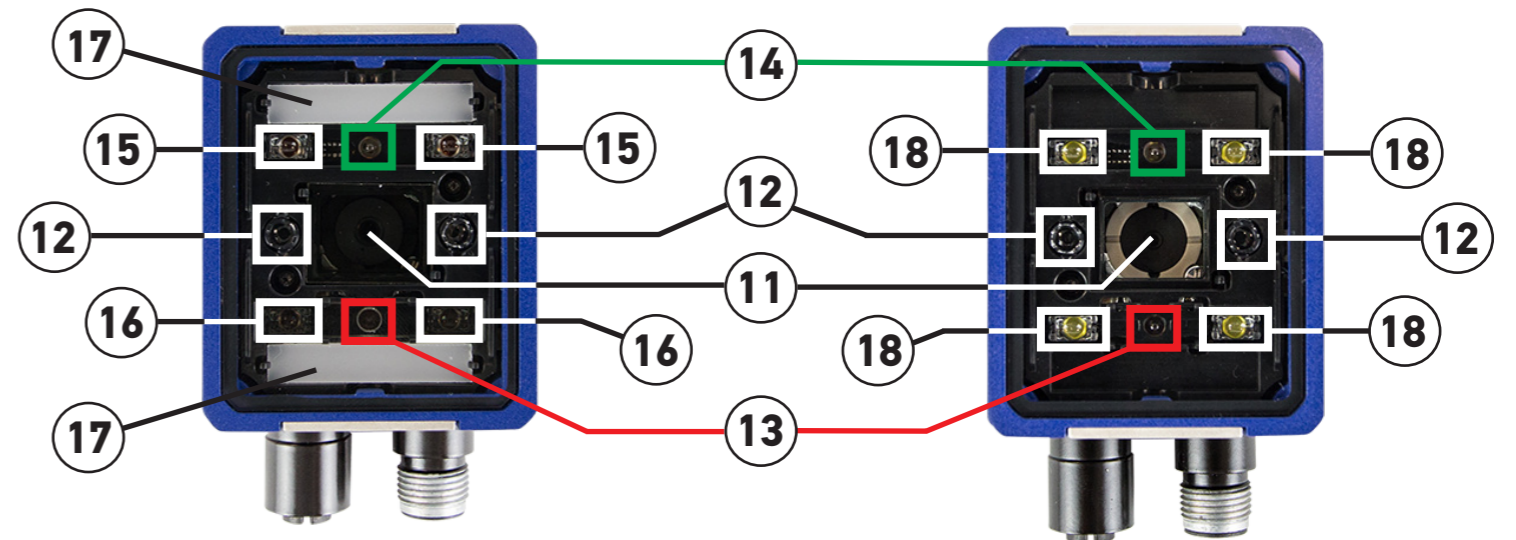

11	Lens
12	LED Aiming System
13	Red Spot (No Read)
14	Green Spot (Good Read)

15	Non Polarized Illuminators
16	Polarized Illuminators
17	Diffused Illuminators
18	Standard Illuminators (Top/Bottom)



**NOTE:** Consult the Product Reference Guide for complete details of all available models.

## CONNECTIONS

### Matrix 220 3xx-x1x models

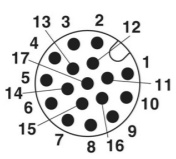
POWER, COM and I/O connector			
M12 male 17 pin			
			
PIN	NAME	FUNCTION	
1	Vdc	Power supply input voltage +	
2	GND	Power supply input voltage -	
Connector Case	CHASSIS	Connector case provides electrical connection to the chassis	
6	I1A	External Trigger A (polarity insensitive)	
5	I1B	External Trigger B (polarity insensitive)	
13	I2A	Input 2 A (polarity insensitive)	
3	I2B	Input 2 B (polarity insensitive)	
9	O1	Output 1	
8	O2	Output 2	
16	O3	Output 3	
14	RX	Auxiliary RS232 RX	
4	TX	Auxiliary RS232 TX	
7	ID+	ID-NET™ network +	
15	ID-	ID-NET™ network -	
PIN	NAME	RS232	RS422 Full Duplex
17	Main Serial Port (sw selectable) (*)	TX	TX+
11		RX	RX+ (*)
12		-	TX-
10		-	RX- (*)

\* DO NOT leave floating. See the PRG for connection details.

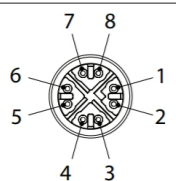
Ethernet connector		
M12 female 8 pin		
		
PIN	NAME	FUNCTION
1	TX+	Transmit data (positive pin)
2	TX-	Transmit data (negative pin)
3	RX+	Receive data (positive pin)
4	RX-	Receive data (negative pin)
5	N.C.	NOT CONNECTED
6	N.C.	NOT CONNECTED
7	N.C.	NOT CONNECTED
8	N.C.	NOT CONNECTED

### Matrix 220 3xx-x4x models

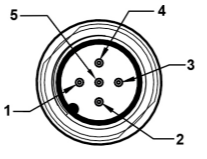
Power Over Ethernet, COM and I/O connector		
M12 male 5 pin		
		
PIN	NAME	FUNCTION
1	I1A	External Trigger A (polarity insensitive)
2	RX	RS232 Main Serial Receive data signal
3	TX	RS232 Main Serial Transmit data signal
4	I1B	External Trigger B (polarity insensitive)
5	GND	RS232 Main Serial Reference signal

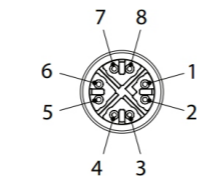

**NOTE: PoE models do not supply power to External Trigger.**

Ethernet connector		
M12 female 8 pin		
		
PIN	NAME	FUNCTION
1	TX+	Transmit data (positive pin)
2	TX-	Transmit data (negative pin)
3	RX+	Receive data (positive pin)
4	RX-	Receive data (negative pin)
5	DC1-	DC Power (negative pin)
6	DC2-	DC Power (negative pin)
7	DC1+	DC Power (positive pin)
8	DC2+	DC Power (positive pin)

## SOFTWARE FEATURES

READABLE CODE SYMBOLOGIES			
1-D and stacked	2-D	POSTAL	Digimarc Barcode
<ul style="list-style-type: none"> <li>•PDF417 Standard and Micro PDF417</li> <li>•Code 128 (GS1-128)</li> <li>•Code 39 (Standard and Full ASCII)</li> <li>•Code 32</li> <li>•MSI</li> <li>•Standard 2 of 5</li> <li>•Matrix 2 of 5</li> <li>•Interleaved 2 of 5</li> </ul>	<ul style="list-style-type: none"> <li>•Codabar</li> <li>•Code 93</li> <li>•Pharmacode</li> <li>•EAN-8/13 - UPC-A/E (including Addon 2 and Addon 5)</li> <li>•GS1 DataBar Family</li> <li>•Composite Symbologies</li> </ul>	<ul style="list-style-type: none"> <li>•Data Matrix ECC 200 (Standard, GS1 and Direct Marking)</li> <li>•QR Code (Standard and Direct Marking)</li> <li>•Micro QR Code</li> <li>•MAXICODE</li> <li>•Aztec Code</li> </ul>	<ul style="list-style-type: none"> <li>•Australia Post</li> <li>•Royal Mail 4 State Customer</li> <li>•Kix Code</li> <li>•Japan Post</li> <li>•PLANET</li> <li>•POSTNET</li> <li>•POSTNET (+BB)</li> <li>•Intelligent Mail</li> <li>•Swedish Post</li> </ul>
<b>Operating Mode</b> CONTINUOUS, ONE SHOT, PHASE MODE			
<b>Configuration Methods</b> X-PRESS™ Human Machine Interface / Windows-based SW (DL.CODE™) via Ethernet / Host Mode Programming sequences sent over Serial or Ethernet TCP interfaces			
<b>Parameter Storage</b> Permanent memory (Flash)			

## TECHNICAL FEATURES

	3xx-x1x	3xx-x4x
<b>ELECTRICAL FEATURES</b>		
<b>Power</b>		
Supply Voltage (Vdc)	10 to 30 Vdc	48 Vdc
Max Consumption (A)	3xx-01x: 0.40 - 0.14 (4.2 W) 3xx-11x: 0.50 - 0.17 (5.1 W)	0.10 (4.8W)
<b>Communication Interfaces</b>		
Main - RS232, RS422 full-duplex	2400 to 115200 bit/s	
Auxiliary - RS232	2400 to 115200 bit/s	
ID-NET™	Up to 1Mbaud	
Ethernet <sup>1</sup>	10/100 Mbit/s	
<b>Inputs</b>		
Opto-coupled and polarity insensitive (see PRG)		
Max Voltage	30 Vdc	
Max Input Current	10 mA	
<b>Outputs</b>		
NPN or PNP short circuit protected (see PRG)		
V <sub>OUT</sub> (I <sub>LOAD</sub> = 0 mA) Max.	30 Vdc	
V <sub>OUT</sub> (I <sub>LOAD</sub> = 100 mA) Max.	3 Vdc	
I <sub>LOAD</sub> Max	100 mA	
<b>OPTICAL FEATURES</b>		
see Product Reference Guide for details		
<b>PHYSICAL FEATURES</b>		
Dimensions	H x W x L	
Std Matrix 220 connector at 0°	78 x 47 x 38 mm (3.1 x 1.9 x 1.5 in)	
Std Matrix 220 connector at 90°	58 x 47 x 58 mm (2.3 x 1.9 x 2.3 in)	
ESD Matrix 220 connector at 0°	78 x 47 x 43 mm (3.1 x 1.9 x 1.7 in)	
ESD Matrix 220 connector at 90°	58 x 47 x 63 mm (2.3 x 1.9 x 2.5 in)	
Weight	173 g. (6.1 oz.)	
Material	Aluminium with plastic protective window cover	
<b>ENVIRONMENTAL FEATURES</b>		
Operating Temperature <sup>2</sup>	-10 to 50 °C (14 to 122 °F) <sup>3</sup>	
Storage Temperature	-20 to 70 °C (-4 to 158 °F)	
Max Humidity	90% non-condensing	
Vibration Resistance EN 60068-2-6	14 mm @ 2 to 10 Hz; 1.5 mm @ 13 to 55 Hz; 2 g @ 70 to 500 Hz; 2 hours on each axis	
Shock Resistance EN 60068-2-27	30g; 11 ms; 3 shocks on each axis	
Protection Class <sup>4</sup> EN 60529	IP65 and IP67	
<b>USER INTERFACE</b>		
LED Indicators	Power; Ready; Good; Trigger; Com; Status; Ethernet Network; Green Spot; (see PRG for other LEDs)	
Other	X-PRESS™ Keypad Button (config. via DL.CODE™)	

1 The embedded Ethernet interface supports application protocols: TCP/IP, EtherNet/IP, Profinet IO, Modbus TCP, OPC UA.

2 High ambient temperature applications should use metal mounting bracket for heat dissipation.

3 Operating temperature is:

• 0 to 50 °C (32 to 122 °F) for the following models: 937900034, 937900035, 937900036, 937900037, 937900038, 937900039, 937900040, 937900041, 937900042

• 0 to 45 °C (32 to 113 °F) for the following models: Matrix 220 3xx-11x.

4 When correctly connected (fully tightened) to IP67 cables with seals.

## COMPLIANCE

Only connect Ethernet and dataport connections to a network which has routing only within the plant or building and no routing outside the plant or building.

### EMC Compliance

In order to meet the EMC requirements:

- connect reader chassis to the plant earth ground by means of a flat copper braid shorter than 100 mm;
- connect pin "Earth" of the CBX connection box to a good Earth Ground;

### European Declaration of Conformity

Hereby, Datalogic S.r.l. declares that the full text of the European Declaration of Conformity is available at: [www.datalogic.com](http://www.datalogic.com). Select the Support & Service > Downloads > Product Certifications link where you can search for your specific product certification.

### UKCA Declaration of Conformity

Hereby, Datalogic S.r.l. declares that the full text of the UKCA Declaration of Conformity is available at: [www.datalogic.com](http://www.datalogic.com). Select the Support & Service > Downloads > Product Certifications link where you can search for your specific product certification.

### FCC Compliance

This device complies with Part 15 of the FCC Rules. Operation is subject to the following two conditions:

- 1) This device may not cause harmful interference
- 2) This device must accept any interference received, including interference that may cause undesired operation.

### EAC Compliance

Customs Union:

The CU Conformity certification has been achieved; this allows the Product to bear the Eurasian mark of conformity.

### Power Supply

**This product is intended to be installed by Qualified Personnel only.**

This product is intended to be connected to a UL Listed Direct Plug-in Power Unit marked LPS or "Class 2".

### LED Safety

According to IEC 62471:2006 all models are exempt (Risk Group 0). According to EN 62471:2008, using limits stated in the directive 2006/25/EC, all models are exempt (Risk Group 0), except model Matrix 220 3U2-01U which is Risk Group 3.

**NOTE:** for Matrix 220 3U2-01U, the measure of the NEAR UV radiation power complies with the Risk Group 0 limit stated by the directive 2006/25/EC only at a distance of 370 mm and farther, instead of the standardized distance of 200 mm.

## PATENTS

See [www.patents.datalogic.com](http://www.patents.datalogic.com) for patent list.

This product is covered by one or more of the following patents:

Design patents: EP004735694

Utility patents: EP0996284B1, EP0999514B1, EP1014292B1, EP1128315B1, EP1396811B1, EP1413971B1, EP2517148B1, EP2649555B1, JP4435343B2, JP4571258B2, US6512218, US6616039, US6808114, US6997385, US7053954, US7387246, US7433590, US8058600, US8368000, US8888003, US8915443, US9268982, US9430689, US9798948, ZL200980163411.X

## EULA

See [www.datalogic.com/eula](http://www.datalogic.com/eula) for consult the End User License Agreement.

## WARRANTY

Refer to the Product Reference Guide for Warranty and additional product information.

# MATRIX 220™

## 快速参考指南



## 基于图像的工业阅读器

### Datalogic S.r.l.

Via San Vitalino 13  
40012 Calderara di Reno (BO)  
Italy  
Tel. +39 051 3147011  
Fax +39 051 3147205

### ©2018-2026 Datalogic S.p.A. 和/或其附属机构

保留所有权利。在不限版权所有权，或未经 Datalogic S.p.A. 和/或其附属机构的书面许可的情况下，不得对此文档的任何一部分进行复制、存储或将其引入检索系统，不得以任何形式、通过任何方法对此文档进行传播，不得将此文档用于任何目的。

特此向 Datalogic 产品的所有者授予复制和传播本文档的非独占性、可撤销性许可，用于买方自身内部的商业用途。买方不得删除或更改本文档包含的任何所有权声明，包括版权声明，并确保所有声明显示在本文档的所有副本中。您可访问 Datalogic 网站 ([www.datalogic.com](http://www.datalogic.com)) 下载本文档的电子版本。如果您访问我们的网站，并想对本文档或其他 Datalogic 出版物提出意见或建议，请通过“联系我们”页面让我们知晓。

### 免责声明

Datalogic 已采取合理措施以在本手册中提供完整而准确的信息，但是对于此文档中所包含的技术上或编辑方面的错误或遗漏，以及由于使用此文档而导致的附带损失或相关后果，Datalogic 概不负责。Datalogic 有权随时更改任何规格，而无需事先通知。

### 商标

Datalogic 和 Datalogic 标志是 Datalogic S.p.A. 在美国和欧盟等诸多国家或地区的注册商标。

Matrix, ID-NET, DL.CODE, 和 X-PRESS 是 Datalogic S.p.A. 和/或其附属机构的商标。所有其他商标和品牌均属于其相关所有者财产。

[www.datalogic.com](http://www.datalogic.com)



821012941 (馬佐. B) 十二月 2026



注释：本快速参考指南不能取代用户手册。您可以通过读取此处的二维码或在 [www.datalogic.com](http://www.datalogic.com) 下载用户手册。



NOTE: Scan this QR code to download the multilingual quick guide.

NOTA: Scansionare questo QR Code per scaricare la guida rapida multilingue.

HINWEIS: Scannen Sie diesen QR-Code, um die mehrsprachige Kurzanleitung herunterzuladen.

NOTA: Escanee este código QR para descargar la guía rápida multilingüe.

REMARQUE: Scannez le code QR suivant pour télécharger le guide rapide multilingue.

OPMERKING: Scan deze QR-code om de meertalige snelgids te downloaden.

ANMÄRKNING: Skanna denna QR-kod för att ladda ner den flerspråkiga snabbguiden.

注释：扫描此二维码下载多语种快速指南。



## 安装程序

1. 安装 Matrix 220 读取器。
2. 进行必要的电气连接。
3. 使用 X-PRESS 界面（瞄准、设置、进行简单配置）或 DL.CODE 软件配置程序（完整配置）配置读取器。

## HMI X-PRESS™ 界面

下表列出了操作模式下五个 LED 指示灯的颜色和含义：

就绪 (绿色)	表示装置已准备好运行。
良好 (绿色)	确认读取成功。
触发器 (黄色)	表示处于读取阶段状态。
COM (黄色)	表示主串行端口正在通讯。
状态 (红色)	表示无读取结果。

在读取器启动阶段（重置或重启阶段），所有 LED 都将闪烁一秒。



HMI X-PRESS™

单按钮可立即访问以下相关功能：

	带可视化条形图的测试模式，可检查静态读取性能。
	开启瞄准，LED 指示器将读取器瞄准目标。目标应在瞄准方块的水平和垂直方向上居中。
	进行设置，自行优化并自动配置光度测定参数。

## 产品概述



1	读取窗口（所示为 ESD 型号）
2	支架安装孔 (2)
3	开机 LED

4	以太网连接 LED
5	90° 旋转接头组
6	HMI X-PRESS™ 界面

### Matrix 220 3xx-x4x



9	以太网供电接头
10	通讯，触发器接头

### Matrix 220 3xx-x1x



7	以太网接头
8	电源 - 通讯 - I/O 接头

### Matrix 220 DPM 型号

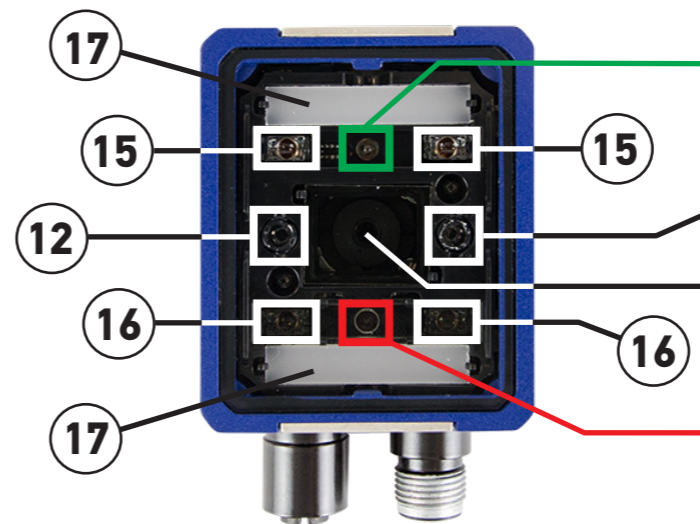

11	镜头
12	LED 瞄准系统
13	红点（无读取）
14	绿点（读取良好）

### Matrix 220 标准型号

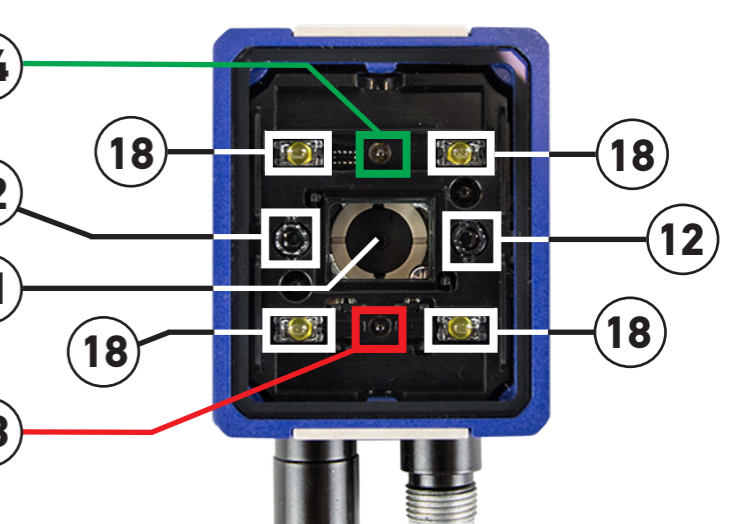

15	非偏振照明器
16	偏振照明器
17	漫射照明器
18	标准照明器（顶部/底部）



注释：关于全部可用车型的完整详细信息，请查阅《产品参考指南》。

