



## CBX800

# INSTALLATION MANUAL



Figure A

- ① Indicator LEDs
- ② Cover Screws (4)
- ③ Host Interface Module Panel
- ④ Compression Connectors (5)
- ⑤ 25-pin Device Connector



**NOTE**

For a complete Gateway configuration using the Genius™ configuration program, refer to the CBX800 Help On-Line available on the downloadable Genius CD zip file. This manual is also downloadable from the Web at [www.datalogic.com](http://www.datalogic.com).

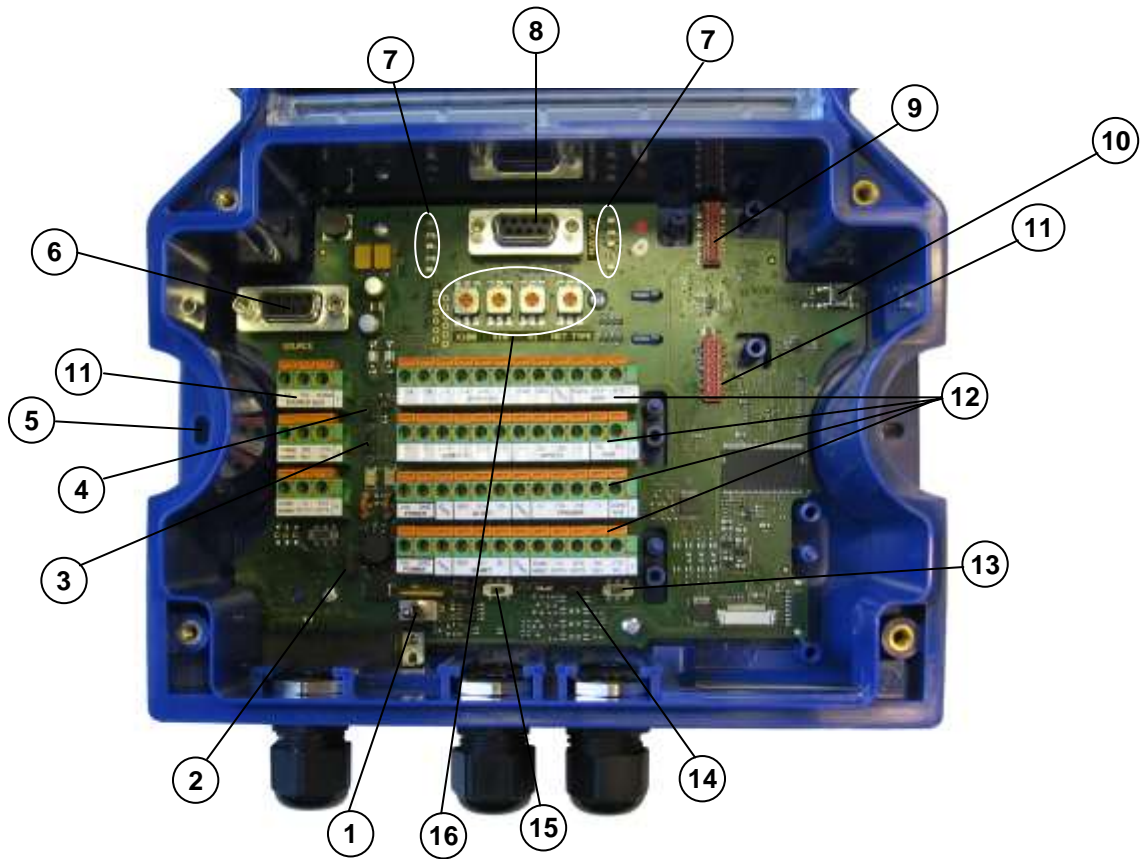


Figure B

- ① Power switch (ON/OFF)
- ② Source Chassis Grounding Selector
- ③ Source Shield Selector
- ④ Power Source Selector
- ⑤ Mounting Holes (2)
- ⑥ Data Source Port Connector
- ⑦ Indicator LEDs
- ⑧ Auxiliary Port Connector
- ⑨ IP65 Host Interface Module Connector
- ⑩ Reset Button
- ⑪ Standard Host Interface Module Connector
- ⑫ Spring Clamp Terminal Blocks
- ⑬ RS485 Termination Resistance Switch
- ⑭ ID-NET/Host Shield Selector
- ⑮ ID-NET Termination Resistance Switch
- ⑯ Network Selection Rotary Switches

## **SUPPORT THROUGH THE WEBSITE**

---

Datalogic provides several services as well as technical support through its website. Log on to **www.datalogic.com** and click on the **SUPPORT > Unattended Scanning Systems** category link. From this page you can select your product model from the dropdown list which gives you access to:

- **Downloads** including Data Sheets, Manuals, Software & Utilities, and Drawings;
- **Repair Program** for On-Line Return Material Authorizations (RMAs) plus Repair Center contact information;
- **Service Program** containing details about Maintenance Agreements;
- **Technical Support** through email or phone.

## **LEGAL NOTICES**

---

© 2009 - 2017 Datalogic S.p.A. and/or its affiliates ♦ ALL RIGHTS RESERVED. ♦ Without limiting the rights under copyright, no part of this documentation may be reproduced, stored in or introduced into a retrieval system, or transmitted in any form or by any means, or for any purpose, without the express written permission of Datalogic S.p.A. and/or its affiliates.

Datalogic and the Datalogic logo are registered trademarks of Datalogic S.p.A. in many countries, including the U.S.A. and the E.U.

ID-NET, and Genius are trademarks of Datalogic S.p.A. and/or its affiliates. All other trademarks and brands are property of their respective owners.

Datalogic shall not be liable for technical or editorial errors or omissions contained herein, nor for incidental or consequential damages resulting from the use of this material.

## DESCRIPTION

---

The CBX800 is a Gateway connection box which can be used as an accessory to facilitate system connections for installation and device replacement of several Datalogic family reading devices.

It allows connection of devices equipped with a standard RS232/RS485 communication interface to the most common Fieldbus systems, by means of a complete range of optional modules, and to ID-NET™ high speed communication network.

System cabling is made through spring clamp terminal blocks inside the CBX800 while the reading device is connected to the CBX800 through a 25-pin connector on the housing.

Two 9-pin connectors placed inside the CBX800 facilitate connection to an external PC for data monitoring or for configuring the CBX800 and the reading device.

Four embedded rotary switches allow easy manual Network Type and Addressing/Baud Rate selection.

CBX800 can also house several accessories which make the system highly flexible. These include:

- One of several Host Interface Modules - to interface the reader with the most popular Fieldbus network types: Ethernet, Profibus; DeviceNet, etc., including IP65 protection versions.
- Mounting Adapters – to provide easy mounting to DIN rails and Bosch profiles.

## PACKAGE CONTENTS

---

Verify that the CBX800 and all the parts supplied with the equipment are present and intact when opening the packaging; the list of parts includes:

- CBX800 Gateway
- Quick Reference Guide
- Mounting screws and washers (2)

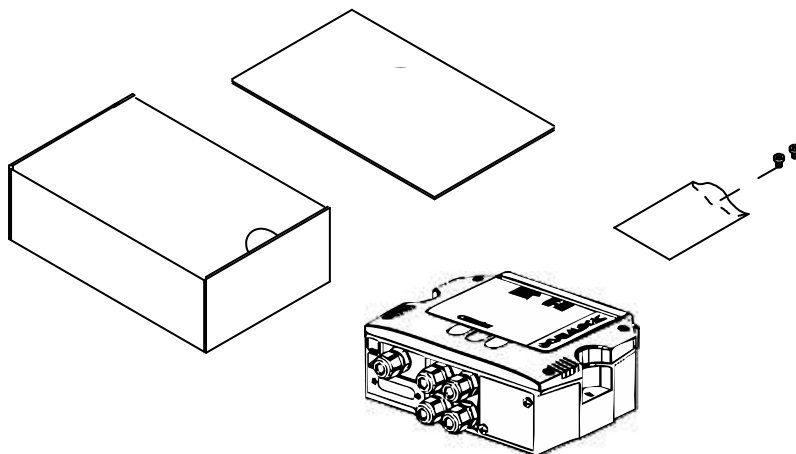


Figure 1 - Package Contents

## ACCESSORIES


The following accessories are available on request for the CBX800:

Name	Description	Part Number
BM200/210	Ethernet TCP/IP Module STD/IP65	93ACC1851, 93ACC1852
BM300/310	Profibus Module STD/IP65	93ACC1810, 93ACC1811
BM400	DeviceNet Module IP65	93ACC1814
BM500/510/520	Ethernet/IP Module STD/IP65/IP54	93ACC1812, 93ACC1813, 93ACC1840
BM600	CANopen Module STD	93ACC1815
BM700/710	Profinet Module STD/IP65	93ACC1816, 93ACC1886
BM1100	CC-Link Module STD	93ACC1845
BM1200/1210	Modbus TCP STD/IP65	93ACC1848, 93ACC1849
BA100	DIN Rail Adapters	93ACC1821
BA200	Bosch Adapters	93ACC1822
BA300	M12 3P F Connector Panel (Service)	93ACC1877
BA400	M12 3P M Connector Panel (External Power)	93ACC1853
BA500	M12 4P F Connector Panel (Trigger)	93ACC1854
BA600	M12 5P F Connector Panel (ID-NET™ Out)	93ACC1855
BA700	M12 5P M Connector Panel (ID-NET™ In)	93ACC1856
BA900	Two Cable Glands Panel	93ACC1847
ADP-MM1	Gender Changer 25P M/M (5 pcs)	93ACC1828


## SUPPORTED READING DEVICES

The CBX800 can be directly connected to all of the following readers through the 25-pin connector illustrated in Figure A.

Linear Scanners				2D Readers
DS2100N	DS2400N	DS4800	DS5100	All Matrix x10 family
DS6x00	DX6400	DS8100A	DX8200A	All Matrix x10N family



**NOTE**      *CBX800 is backward compatible with DS2100N/DS2400N (black body), DS4600A, and DS1100/DS2200 10-30 Vdc model reading devices using the ADP-MM1 25-pin gender changer. See the Gender Changer documentation for the relative CBX pinout.*




**NOTE**      *For 6/8K family scanners having software version 6.80 or later, an alternative fixed speed (57600 baud) ID-NET™ layout can be made without the use of CBX800. See the ID-NET™ Application Note on the downloadable Genius mini-DVD file for details.*  
*For maximum ID-NET™ network performance use CBX800.*

A Hand-Held reader can also be connected to the 25-pin connector and have its data passed through to the Host or ID-NET network.

## OPENING THE CBX800

---

To install the CBX800 or during normal maintenance, it is necessary to open it by unscrewing the four cover screws:



*The CBX800 must be disconnected from the power supply during this operation.*

**CAUTION**

## ACCESS TO INTERNAL PARTS

---

To make installation and replacement easier, the CBX800 is made up of three parts:

- 1) the body of the device containing all electronic components and optional boards
- 2) the transparent removable cover for inspection and for easy access to spring clamps and internal modules
- 3) the removable front connector panel providing easy access to the optional interface modules

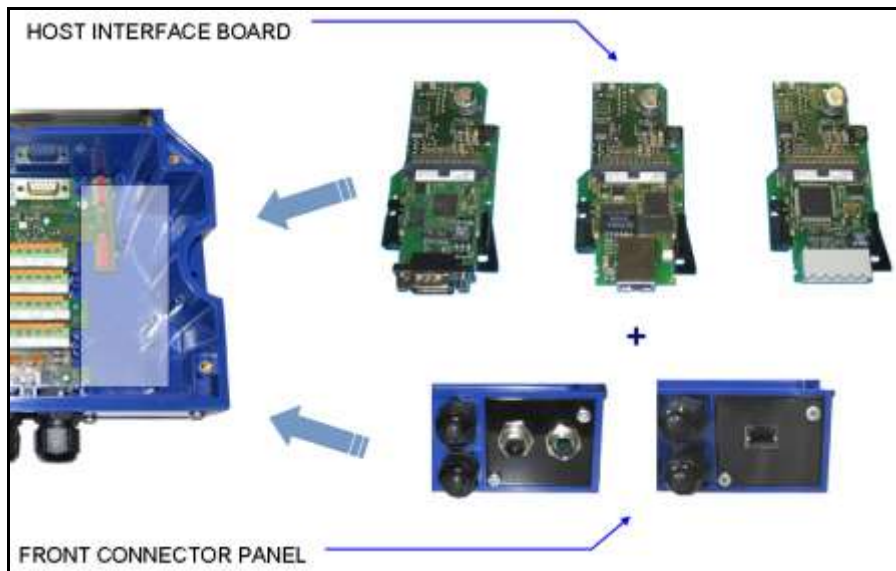


Figure 2 – CBX800 Front Connector Panel

## MECHANICAL INSTALLATION

CBX800 can be mounted to various wooden or plastic surfaces using two self-threading screws (3.9 x 45 mm) and washers.

Mounting to other surfaces such as concrete walls or metallic panels requires appropriate user-supplied parts (screws, screw anchors, nuts, etc).

CBX800 can also be mounted to a DIN rail or a Bosch Frame using the following mounting accessories: BA100 (93ACC1821), BA200 (93ACC1822).

The diagram below gives the overall dimensions of the CBX800 and shows the two mounting through-holes.

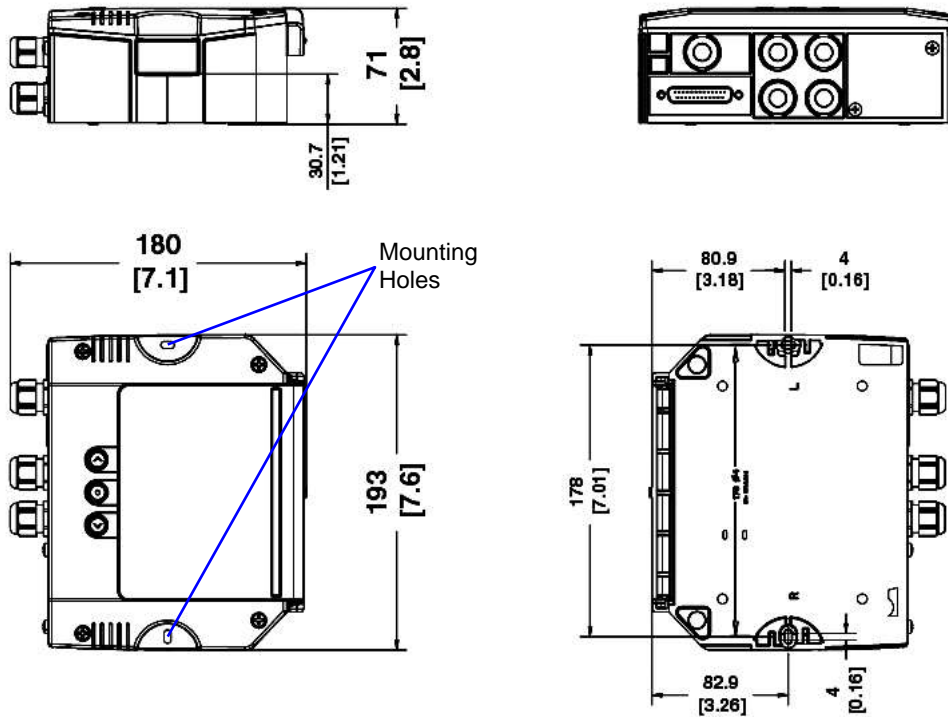



Figure 3 - Overall Dimensions

## POWER SUPPLY

The power switch (see Figure 4) switches the power supply ON or OFF for both the CBX800 and the connected reading device.



**CAUTION**

*The power switch does not control power to the Vdc/GND, +V/-V spring clamps, therefore any devices connected to these signals (i.e. external trigger, encoder, etc.), are live and are not protected from polarity inversion. Disconnect the power supply when working inside the CBX800.*



Figure 4 - Power Switch ON/OFF Positions



**NOTE**

*Vdc is electrically connected to +V, just as GND is electrically connected to -V. This is useful for supplying external trigger, inputs and outputs from the CBX800 power source, however +V and -V signals should not be used as power supply inputs to the CBX800.*

**The power supply must be between 10 and 30 Vdc only.**

## **SYSTEM WIRING**

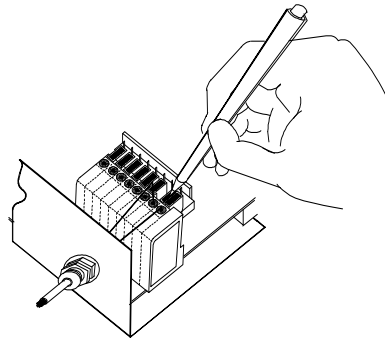
---

The connection and wiring procedure for CBX800 is described as follows:

- 1) Open the CBX800 by unscrewing the four cover screws.
- 2) Verify that the CBX800 power switch is off (see Figure 4).
- 3) Unscrew the compression connectors and pass all the system cables through them into the CBX800 housing.
- 4) To connect the power and input/output signals:
  - Prepare the individual wires of the system cables by stripping the insulation back approximately 1 cm.
  - Using a device such as a screwdriver, push down on the lever directly next to the clamp (see Figure 5).
  - Insert the wire into the clamp and release the lever.

The wire will now be held in the spring clamp.

- 5) Tighten the compression connector nuts so that the internal glands seal around the cables.



**Figure 5 - System Cable Connections**

Flexible stranded wire should be used and must meet the following specifications.

All positions:    24 - 16 AWG    0.2 - 1.5 mm<sup>2</sup>

The CBX800 spring clamp connector pinouts are indicated in the Pinout table.

**Refer to the reading device Installation Manual for signal details.**



# PINOUT


Pinouts				
Group	Name	Function		
Input Power	Vdc	Power Supply Input Voltage +		
	GND	Power Supply Input Voltage -		
	Earth	Protection Earth Ground		
External Trigger Input	+V	Power Source – External Trigger		
	I1A	External Trigger A (polarity insensitive)		
	I1B	External Trigger B (polarity insensitive)		
	-V	Power Reference – External Trigger		
Generic Input	+V	Power Source – Inputs		
	I2A	Input 2A (polarity insensitive)		
	I2B	Input 2B (polarity insensitive)		
	-V	Power Reference – Inputs		
Outputs	+V	Power Source – Outputs		
	-V	Power Reference – Outputs		
	O1+	Output 1+		
	O1-	Output 1-		
	O2+	Output 2+		
	O2-	Output 2-		
Other I/O	O3A	Output 3+ (polarity sensitive)		
	O3B	Output 3- (polarity sensitive)		
	+V	Power Source – Other I/O		
	I3A	Input 3A (polarity insensitive)		
	I4A	Input 4A (polarity insensitive)		
	-V	Power Reference – Other I/O		
	I34B	Input 3B and 4B (common) (polarity insensitive)		
I34B	Input 3B and 4B (common) (polarity insensitive)			
Auxiliary Interface <sup>(1)</sup>	TX	Auxiliary Interface TX		
	RX	Auxiliary Interface RX		
	SGND	Auxiliary Interface Reference		
ID-NET™	REF	Network Reference		
	ID+	ID-NET™ network +		
	ID-	ID-NET™ network -		
Network	Shield	Network Cable Shield		
Data Source Auxiliary Interface <sup>(2)</sup>	TX	Data Source Aux TX		
	RX	Data Source Aux RX		
	SGND	Data Source Aux Reference		
Data Source Interface		<b>RS232</b>	<b>RS485FD</b>	<b>RS485HD</b>
		TX	TX+	RTX+
		RTS	TX-	RTX-
		RX	*RX+	
		CTS	*RX-	
		SGND	SGND	SGND
Host Interface		<b>RS232</b>	<b>RS485FD</b>	<b>RS485HD</b>
		TX	TX+	RTX+
		RTS	TX-	RTX-
		RX	*RX+	
		CTS	*RX-	
		SGND	SGND	SGND

\* Do not leave floating, see Reading Device Reference Manual for connection details.

<sup>(1)</sup> The Auxiliary Interface group is connected to the 9-pin Auxiliary connector and is used for configuring the CBX800 parameters through Genius™, the multilanguage software tool.

<sup>(2)</sup> The Data Source Auxiliary group is connected to the 9-pin Data Source connector and is used for configuring Genius-compatible reading devices through Genius™, the multilanguage software tool.


The input power signals **Vdc**, **GND** and **Earth** as well as the network signals **REF**, **ID+**, **ID-** and **Shield**; and **RTX+**, **RTX-** and **SGND** are repeated to facilitate system cabling. In this way the power and network busses can enter and exit the CBX800 from different spring clamps but be physically connected together.



**NOTE**

To avoid electromagnetic interference:

- Connect CBX800 Protection Earth (Earth) to a good earth ground.
- Connect the reading device chassis to earth ground through the jumper, (default setting, see Figure 7).
- Connect the Network Cable Shield (Shield) to Filtered Earth through the jumper (default setting, see Figure 6).



**CAUTION**

Do not connect to the Host Interface spring clamp terminals if using Host Interface Modules (Fieldbus and non Fieldbus).

## JUMPER SETTINGS

### POWER SOURCE JUMPER SETTINGS

For most applications input power is provided through the dedicated spring clamp connectors inside the CBX800.

However CBX800 may accept power from the connected reading device through the 25-pin connector. This is useful, for example, to pass power to connected accessories such as Encoder and Presence Sensor from DX8200A VAC models or 6K/8K scanners powered directly through the network. See the relative reading device Reference Manual for details.

To power CBX800 from the reading device, the power source jumper must be placed in the "power from device" position as indicated in Figure 6.

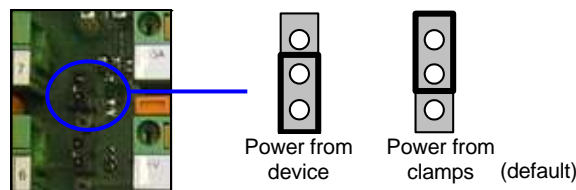


Figure 6–Power Source Jumper Settings

### SOURCE SHIELD JUMPER SETTINGS

The reading device shield (Shield) can be connected to Earth Ground (Earth) either directly or through a filter circuit. If the jumper is left open, the network cable shield (Shield) is floating.

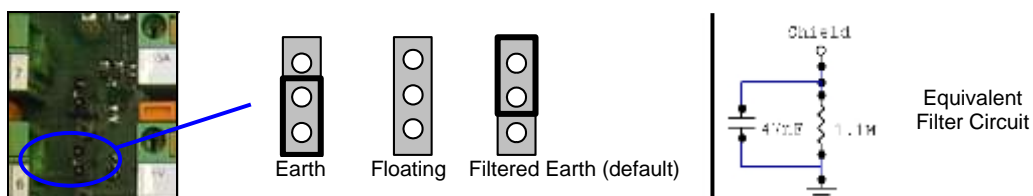


Figure 7– Source Shield Jumper Settings

## SOURCE CHASSIS GROUNDING JUMPER SETTINGS

The reading device chassis grounding method can be selected by positioning a jumper (see Figure 8 ). In this way the reading device chassis can be connected to earth ground (only if pin Earth is connected to a good earth ground). For all reading devices except 6K/8K, the chassis can alternatively be connected to the power supply ground signal (GND) or it can be left floating but, in this case, the jumper must be removed. For 6K or 8K scanners the chassis is internally connected to GND.

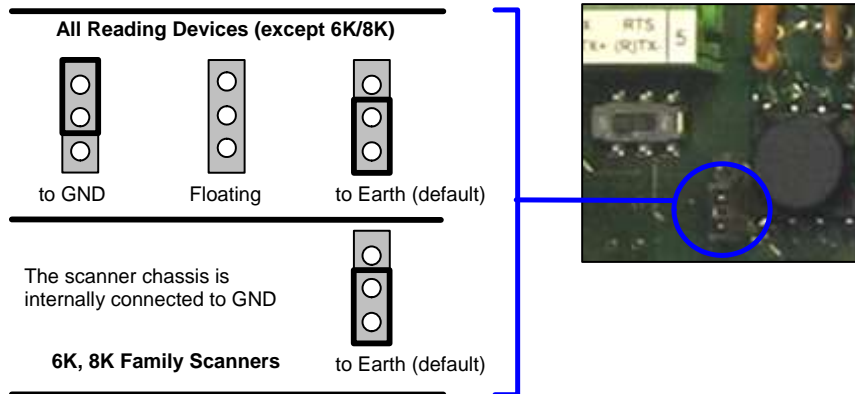


Figure 8 – Chassis Grounding

## ID-NET/HOST SHIELD JUMPER SETTINGS

The Network shield (Shield) can be connected to Earth Ground (Earth) either directly or through a filter circuit. If the jumper is left open, the network cable shield (Shield) is floating.

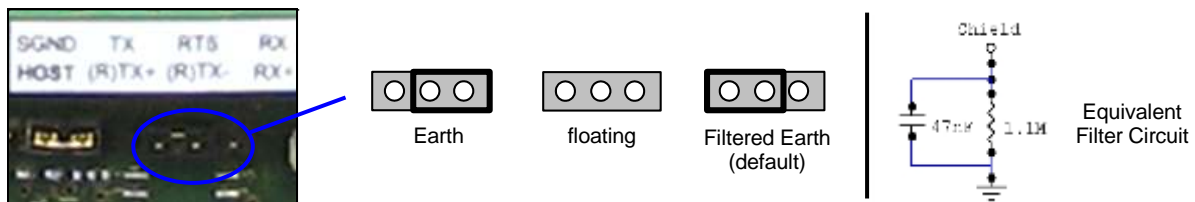


Figure 9 – ID-NET/Host Shield Jumper Settings

## NETWORK BUS TERMINATION

### ID-NET™

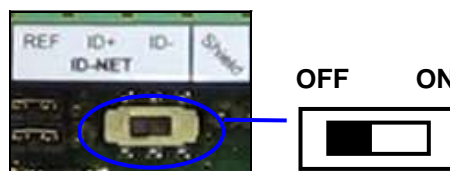



Figure 10 – ID-NET™ Termination Resistance Switch

The ID-NET™ termination resistance switch enables or disables the insertion of the bus termination resistor for ID-NET™ network applications.



**CAUTION**

*In ID-NET™ network applications the termination resistor must be enabled ONLY on the first and last devices of the chain. On all the other devices this resistor MUST NOT be enabled (OFF).*

## RS485 HD

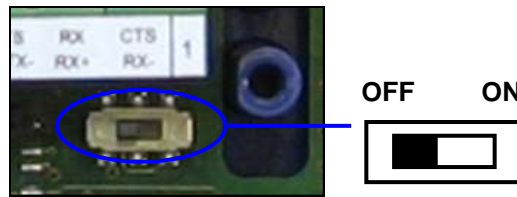



Figure 11 – RS485 HD Termination Resistance Switch

The RS485 HD termination resistance switch enables or disables the insertion of the bus termination resistor for RS485 Half Duplex Multidrop applications.



**CAUTION**

*In Multiplexer applications the termination resistor must be enabled **ONLY** on the last device of the chain, the farthest away from the Multiplexer (assuming the Multiplexer is the first device of the chain). **On all the other devices this resistor MUST be OFF (disabled).***

***This switch must also be OFF (disabled) when Fieldbus Modules are used.***

## NETWORK PARAMETER SELECTORS

Four embedded rotary switches allow easy manual selection of network parameters.

As shown in Figure 12 , the Net Type rotary switch allows Network Type selection , while three dedicated rotary switches (X1, X10, X100) can be used for manually selecting Addressing and Baud Rate.

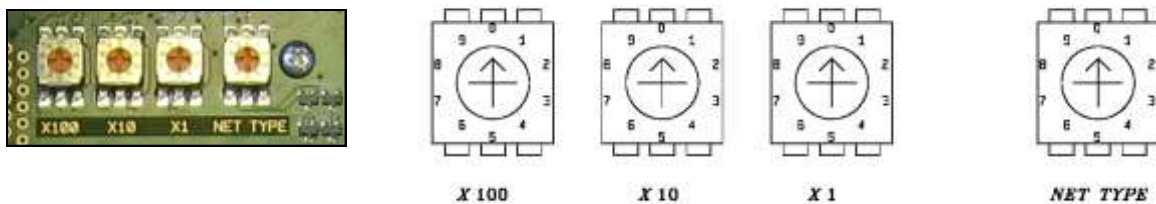


Figure 12 – Network Parameter Selectors

## NETWORK TYPE SELECTION

The network type depends on the application layout and installed accessories.

Net Type Switch
0 = None (no Host Interface Module Present)
1 = Ethernet/IP
2 = Profibus
3 = DeviceNet
4 = CC-Link
5 = Profinet
6 = CANopen
7 = Software Configuration Controlled Host Interface Network
8 = Not Available
9 = ID-NET™ Slave Multidata

The Net Type selector switch allows setting the Gateway type: Serial (None), Fieldbus, ID-NET™ network:

- all non network applications (Typology Role = Other) must be set to **None (0)**.
- ID-NET™ Slaves must be set to **Slave Multidata (9)**, (same ID-NET™ network Topology Role as the ID-NET™ Master).

Through the CBX800, several types of accessory Host Interface Modules are available to connect the CBX800 Gateway to a Host network as a Slave node of that network. **Note: ID-NET™ Multidata Slaves (9) exclude Host Interface Module configuration.**

The Net Type switch settings **(1 – 6)** assign the Host network type through the hardware switch; the Node Address is assigned by the Network Address Selection switches. These settings override the software configuration and therefore when used, **must** match the actual Host Interface Module.

The Net Type switch setting **Software Configuration Controlled Host Interface Network (7)** allows the Host network type and Node Address to be set through the software configuration program; the hardware switches are ignored. This position is valid for all the Host network types including Module types that have no hardware switch position (i.e. Modbus TCP or Ethernet TCP/IP).

## NETWORK ADDRESS SELECTION

Hardware network address selection is provided for rapid installation of ID-NET™ networks and for some of the Host Interface Modules. These switch settings are read at each power-up or reset, and override software configuration settings except where specified otherwise. Valid address selection depends on the network type:

### Ethernet/IP and Profinet

The Ethernet IP or Profinet address refers to the last three digits of the IP address (i.e. 172.16.11.xxx). The valid selection range is from 000 to 255. Address selections outside of this range are not accepted by the network.

#### IP Addressing

There are a few special switch settings that allow the software to determine the IP address for Ethernet IP and Profinet interfaces. These settings correspond to the *IP Addressing* parameter in Genius™.

777 = Remote Assignment through the IPConfig application available on the downloadable mini-DVD file.

888 = Static Assignment – set manually through Genius™

999 = set through a DHCP server

### Profibus

The valid selection range for the Profibus address is from 000 to 126. Address selections outside of this range are not accepted. Address 126 is a special address which allows the Profibus Master, through software, to set the node address in the range from 000 to 125.

### DeviceNet

The valid selection range for the DeviceNet address is from 00 to 64. Address selections outside of this range are not accepted. The x100 switch is ignored. Address 64 is a special address which allows the DeviceNet Master, through software, to set the node address in the range from 00 to 63.

### CC-Link

The valid selection range for the CC-Link address is from 01 to 64. Address selections outside of this range are not accepted. The x100 switch is ignored. See the Help On-Line *Node Address* parameter for address restrictions.

### CANopen

The valid selection range for the CANopen address is from 001 to 128. Address selections outside of this range are not accepted. Address 128 is a special address which allows the CANopen Master, through software, to set address and baud rate.


### ID-NET™

The valid selection range for the ID-NET™ Slave addresses is from 01 to 31. Address selections outside of this range are not accepted by the ID-NET™ network. The x100 switch in this case refers to the ID-NET™ baudrate.

## BAUDRATE SELECTION

The Host network baudrates cannot be set through the rotary switches.

When the Network Type is used for ID-NET™ network Slaves, the ID-NET™ baudrate is selected through the x100 switch and must match the Master ID-NET™ baudrate. The settings are:

ID-NET™ Baudrate Switch (x100)		
	0 = 19200 Baud	5 = 500 kBaud
	1 = 38400 Baud	6 = 1 MBaud
	2 = 57600 Baud	7 = Reserved
	3 = 125 kBaud	8 = Reserved
	4 = 250 kBaud	9 = Reserved

## RESET CBX800 TO FACTORY DEFAULT (OPTIONAL)

If it ever becomes necessary to reset the CBX800 to the factory default values, you can perform this procedure by holding the Reset push button ( Figure B, #10) pressed while powering up the CBX800.

At the end of the procedure (about 5-6 seconds), the Configuration and Environmental parameters are reset and the LEDs: TRIGGER, IN 2, and READY blink simultaneously 3 times.

On the CBX800 display module, the message "Default Set" is shown on the display.

## ELECTRICAL CONNECTIONS

### POWER SUPPLY

CBX00 can accept power from the connected reading device through the 25-pin connector, or through the dedicated spring clamp connector (see section **Power Source Jumper Settings**).

The default jumper setting, requires power to be supplied to the CBX800 through the Vdc and GND pins provided on the spring clamp terminal connector as shown in Figure 13:

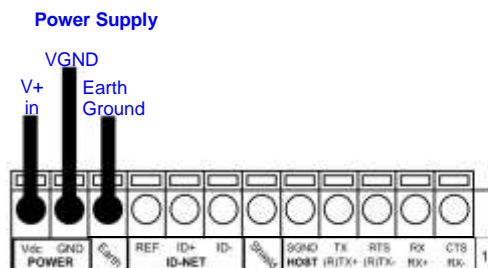


Figure 13 - Power Supply Connections

The power must be between 10 and 30 Vdc only.

## HOST INTERFACE



**CAUTION**

*Do not connect to the Host Interface spring clamp terminals if using Host Interface Modules (Fieldbus and non Fieldbus).*



**Figure 14 – Host Interface Module**

The signals relative to the following Serial interface types are available on the CBX800 spring clamp terminal blocks.

**The Host serial interface type and its parameters (baud rate, data bits, etc.) can be defined by the user via Genius™ software. The RS485 half duplex is automatically set whenever MUX32 communication protocol is enabled. For more details refer to the "Communication Settings" section in the Genius™ Help On Line.**

Details regarding the connections and use of the interfaces are given in the next paragraphs.

## Host RS232 Interface

The RS232 interface can be used for connections to the host computer allowing transmission of code data.

The following pins are used for RS232 interface connection:

Pinout	Function
TX	Transmit Data
RX	Receive Data
RTS	Request To Send
CTS	Clear To Send
SGND	Signal Ground

It is always advisable to use shielded cables. The overall maximum cable length must be less than 15 m (49.2 ft).

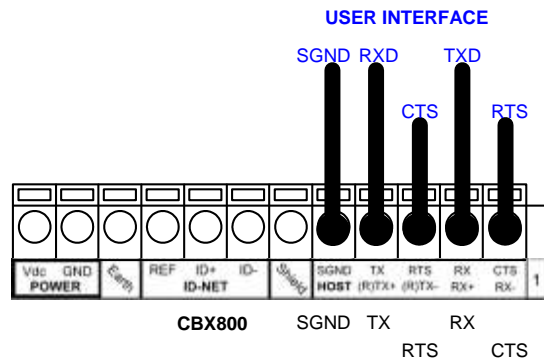


Figure 15 – RS232 Host Interface Connections Using Hardware Handshaking

The RTS and CTS signals control data transmission and synchronize the connected devices.

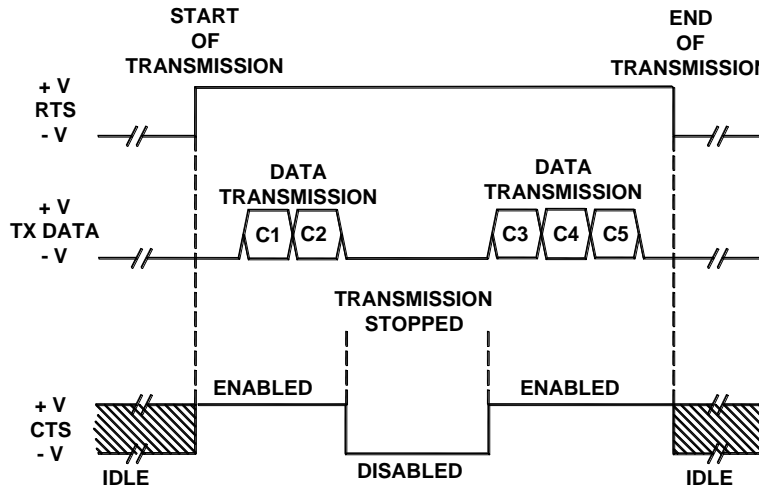


Figure 16 - RS232 Control Signals

If the RTS/CTS handshaking protocol is enabled, the reading device activates the RTS output to indicate a message is to be transmitted. The receiving unit activates the CTS input to enable the transmission.



## Host RS485 Full-Duplex Interface

The RS485 full-duplex (5 wires + shield) interface is used for non-pollled communication protocols in point-to-point connections over longer distances (max 1200 m / 3940 ft) than those acceptable for RS232 communications or in electrically noisy environments.

The CBX800 pinout follows:

Pinout	Function
TX+	RS485 Transmit Data +
RX+	RS485 Receive Data +
TX-	RS485 Transmit Data -
RX-	RS485 Receive Data -
SGND	Signal Ground

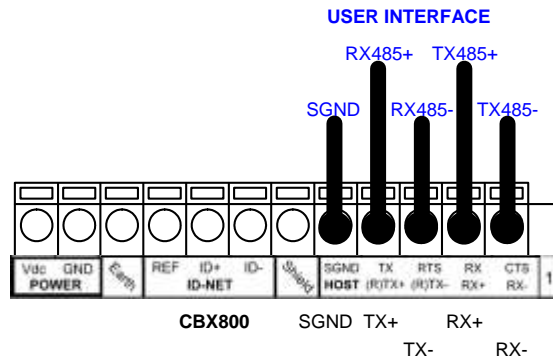


Figure 17 - RS485 Full-duplex Connections



**NOTE**

For applications that do not use RX485 signals, do not leave these lines floating but connect them to SGND as shown below.

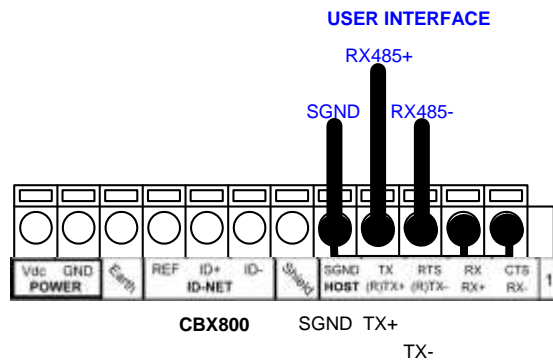


Figure 18 - RS485 Full-duplex Connections using Only TX Signals

## Host RS485 Half-Duplex Interface

The RS485 half-duplex (3 wires + shield) interface is used for polled communication protocols.

It can be used for Multidrop connections with a Datalogic MX4000 Multiplexer, exploiting a proprietary protocol based on polled mode called MUX32 protocol, where a master device polls slave devices to collect data.

Pinout	Function
RTX+	RS485 Receive/Transmit Data +
RTX-	RS485 Receive/Transmit Data -
SGND	Signal Ground

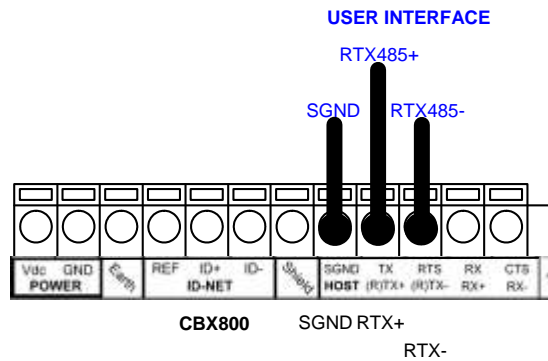


Figure 19 - RS485 Half-duplex Connections

This interface is forced by software when the protocol selected is MUX32 protocol.

In a Multiplexer layout, the Multidrop address must also be set via serial channel by the Genius™ utility or by the Host Programming Mode.

## ID-NET™ INTERFACE

The following pins are used to connect the ID-NET™ interface:

Pinout	Function
Shield	Network Cable Shield
ID+	ID-NET™ network +
ID-	ID-NET™ network -
REF	Network Reference

## AUXILIARY INTERFACE

All CBX800s have an RS232 auxiliary interface available on the 9-pin connector below, which can be linked to another host computer or an external system. This interface is mainly used for CBX800 configuration through Genius™, the multilanguage software tool. Diagnostics and program downloading can be performed from this interface.

Connections can be made to a PC or Laptop using a straight through cable or a USB-RS232 converter.



Figure 20 - 9-pin D-Sub Female Connector

With reference to the 9-pin connector of Figure 20, the following pins are used to connect the RS232 auxiliary interface:

Pin	Name	Function
2	TX	Auxiliary Interface Receive Data
3	RX	Auxiliary Interface Transmit Data
5	SGND	Signal Ground
1, 4, 6, 7, 8, 9		N.C.

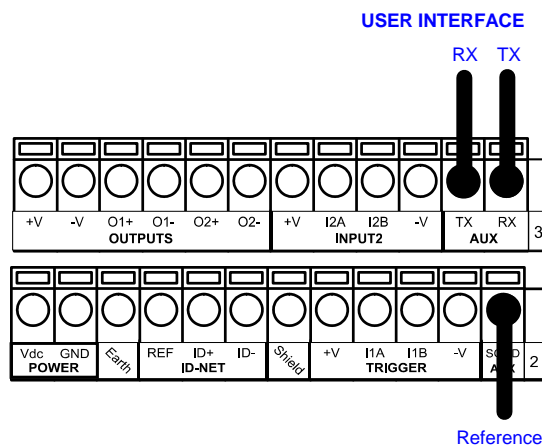


Figure 21 - RS232 Auxiliary Interface Connections



**NOTE**

*Do not connect the Aux Interface to the CBX spring clamp connectors and the 9-pin connector simultaneously.*

## DATA SOURCE INTERFACE

The Data Source port can be used for configuration and data monitoring purposes. It allows full RS232/RS485 connectivity and is software selectable.

### Data Source RS232 Interface

The following pins are used for RS232 interface connections:

Pinout	Function
TX	Transmit Data
RX	Receive Data
RTS	Request To Send
CTS	Clear To Send
SGND	Signal Ground

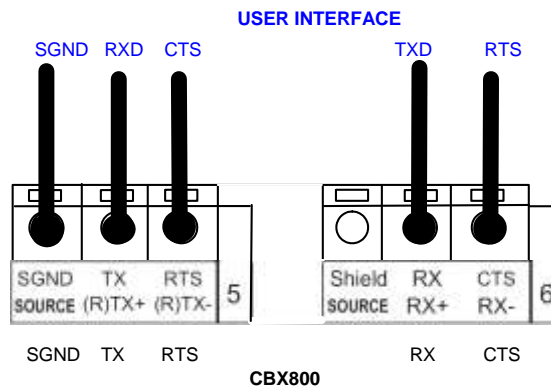


Figure 22 – RS232 Data Source Interface Connections

### Data Source RS485 Full-Duplex Interface

The following pins are used for RS485 Full-duplex interface connections:

Pinout	Function
TX+	RS485 Transmit Data +
RX+	RS485 Receive Data +
TX-	RS485 Transmit Data -
RX-	RS485 Receive Data -
SGND	Signal Ground

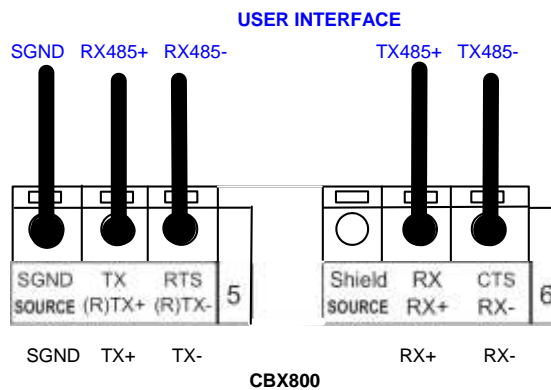

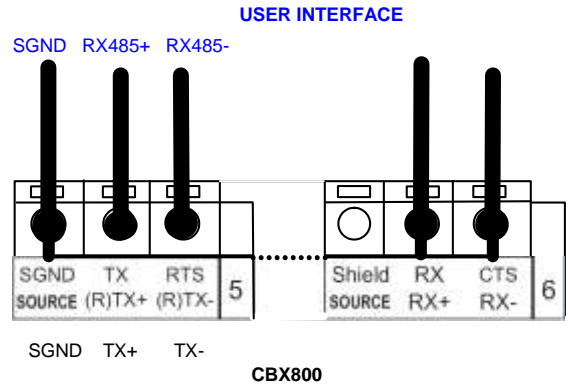


Figure 23 - RS485 Full-duplex Connections

 **NOTE** For applications that do not use RX485 signals, do not leave these lines floating but connect them to SGND as shown below.



**Figure 24 - RS485 Full-duplex Connections using Only TX Signals**

## DATA SOURCE AUXILIARY INTERFACE

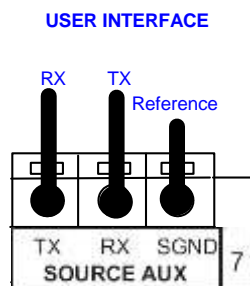
The Data Source Auxiliary Interface available on the 9-pin connector below is used for configuring the external reading device parameters.



**Figure 25 - 9-pin D-Sub Female Connector**

With reference to the 9-pin connector of Figure 25, the following pins are used to connect the Data Source Auxiliary Interface:

Pin	Name	Function
2	TX	Data Source Aux Interface Receive Data
3	RX	Data Source Aux Interface Transmit Data
5	SGND	Signal Ground
1, 4, 6, 7, 8, 9		N.C.




**Figure 26 – Data Source Auxiliary Interface Connections**

## INPUTS

The two optocoupled polarity insensitive inputs, Input 1 (External Trigger Input) and Input 2, a generic input, available on the CBX800 spring clamp terminal blocks, are managed by the reader connected to the 25-pin connector.

These inputs are optocoupled and can be driven by both NPN and PNP type commands.



*Polarity insensitive inputs assure full functionality even if pins A and B are exchanged.*


**NOTE**

### External Trigger Input (Input 1)

The connections are indicated in the following diagram:

Pinout	Function
+V	Power Source - External Trigger
I1A	External Trigger A (polarity insensitive)
I1B	External Trigger B (polarity insensitive)
-V	Power Reference - External Trigger

#### EXTERNAL TRIGGER INPUT CONNECTIONS USING CBX800 POWER



*Power is available directly to the Input Device, independently from the Power Supply Switch inside the CBX800.*

**CAUTION**

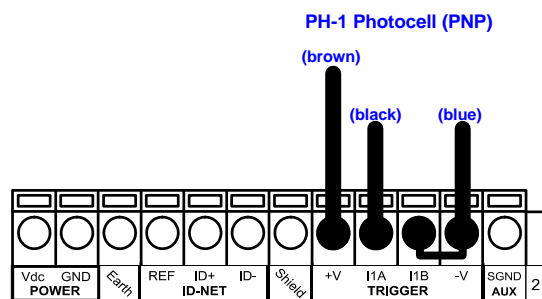


Figure 27 – PH-1 External Trigger Using CBX800 Power

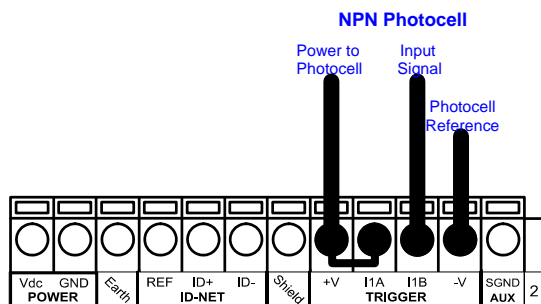


Figure 28 - NPN External Trigger Using CBX800 Power

EXTERNAL TRIGGER INPUT CONNECTIONS USING EXTERNAL POWER

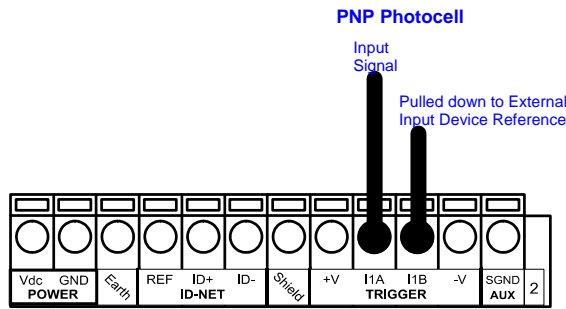


Figure 29 - PNP External Trigger Using External Power

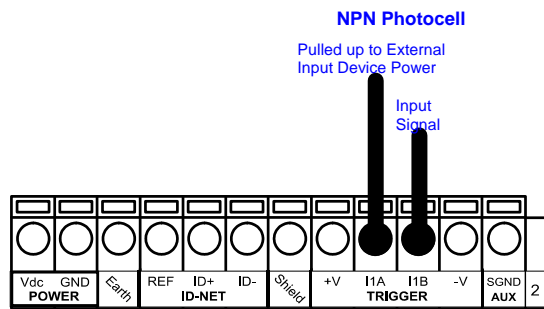



Figure 30 - NPN External Trigger Using External Power

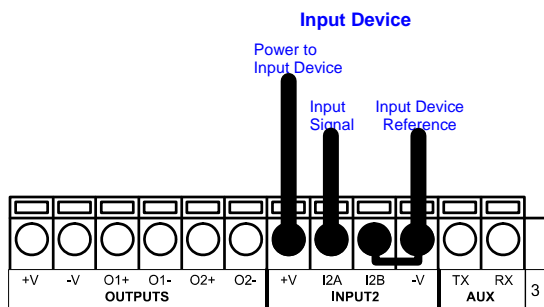
Generic Input (Input 2)

Pinout	Function
+V	Power Source – Inputs
I2A	Input 2 A (polarity insensitive)
I2B	Input 2 B (polarity insensitive)
-V	Power Reference - Inputs

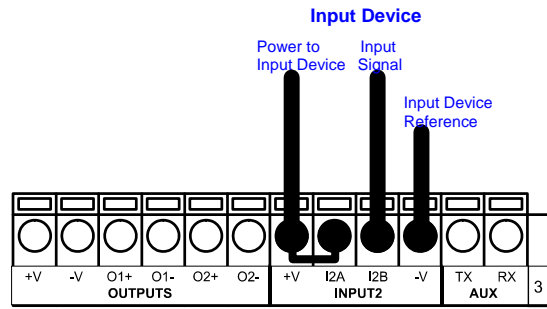
INPUT 2 CONNECTIONS USING CBX800 POWER



**CAUTION** *Power is available directly to the Input Device, independently from the Power Supply Switch inside the CBX800.*



PNP Input 2 Using CBX800 Power



NPN Input 2 Using CBX800 Power

INPUT 2 CONNECTIONS USING EXTERNAL POWER

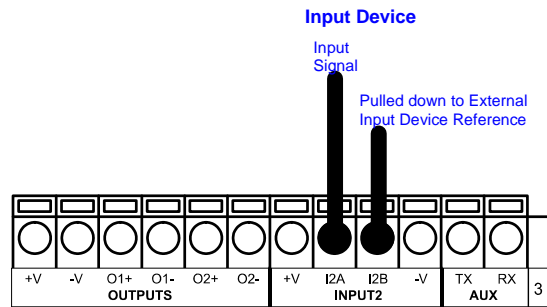


Figure 31 - PNP Input 2 Using External Power

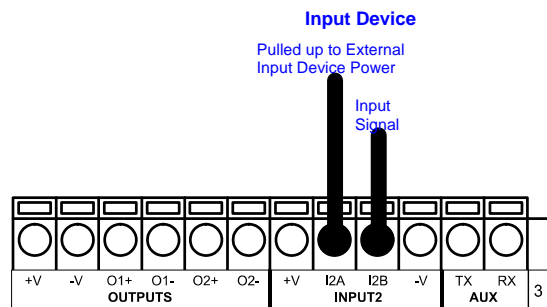


Figure 32 - NPN Input 2 Using External Power


OUTPUTS

The two optocoupled general purpose outputs available on the CBX800 spring clamp terminal blocks are managed by the reader connected to the 25-pin connector. The meaning of the two outputs Output 1 and Output 2 can be defined by the user. They are typically used either to signal the data collection result or, for 2D readers, to control an external lighting system.

Pinout	Function
+V	Power Source - Outputs
O1+	Output 1 +
O1-	Output 1 -
O2+	Output 2 +
O2-	Output 2 -
-V	Power Reference Outputs

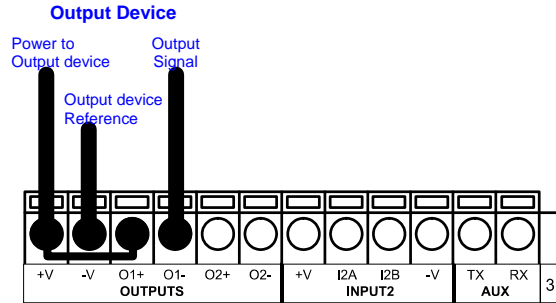


**OUTPUT CONNECTIONS USING CBX800 POWER**

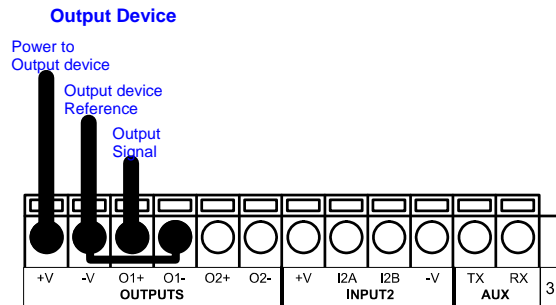


**CAUTION**

*Power is available directly to the Output Device, independently from the Power Supply Switch inside the CBX800.*

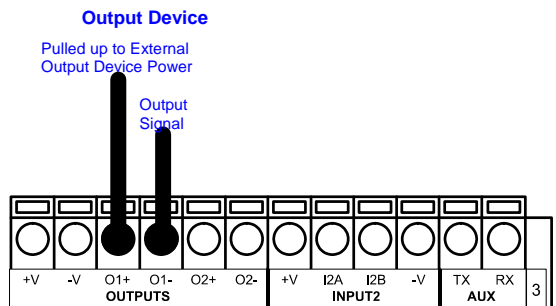


**Figure 33 - Open Emitter Output Using CBX800 Power**

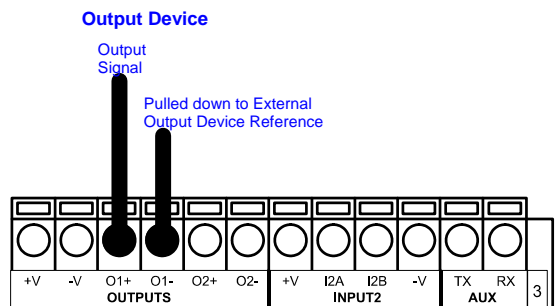


**Figure 34 - Open Collector Output Using CBX800 Power**

**OUTPUT CONNECTIONS USING EXTERNAL POWER**



**Figure 35 - Output Open Emitter Using External Power**



**Figure 36 - Output Open Collector Using External Power**

## OTHER I/O

Two further input signals and one output signal, are available on the CBX800 for readers that support them.

These further input/output options are:

- two optocoupled polarity insensitive inputs (Input 3 and Input 4)
- one optocoupled polarity sensitive output (Output 3)

The connections are indicated in the following diagram:

Pinout	Function
O3A	Output 3+ (polarity sensitive)
O3B	Output 3- (polarity sensitive)
+V	Power Source – Other I/O
I3A	Input 3A (polarity insensitive)
I4A	Input 4A (polarity insensitive)
-V	Power Reference – Other I/O
I34B	Input 3B and 4B (common) (polarity insensitive)
I34B	Input 3B and 4B (common) (polarity insensitive)



**NOTE**

*The label for Output 3 shows 3A and 3B but this output is polarity sensitive for CBX800 (3A = 3+ and 3B = 3-).*

## INDICATOR LEDs

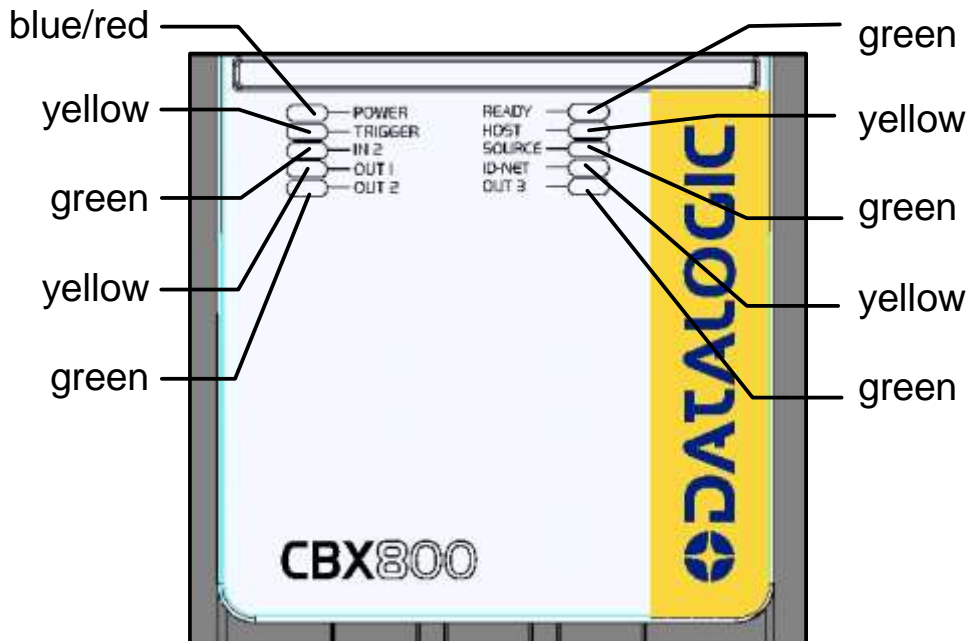



Figure 37 – Indicator LEDs

There are ten Indicator LEDs which signal power, communication, and I/O activity and are visible from the CBX800 outside cover.

The Power LED is blue when power is correctly applied to the CBX800 and the power switch is turned on.

This LED is red if power polarity is incorrect. In this case the connected reading device is protected.



**CAUTION** *If external I/O devices are powered through CBX800 (connected to +V/-V), they are not protected from polarity inversion.*

The Ready LED is on after the power-up or reset sequence is complete.

The Host, Source, and ID-NET LEDs are active when communicating on the respective interface (fast blinking).

The remaining I/O LEDs are active when the respective I/O is active depending on the software configuration setting.

## TYPICAL LAYOUTS

The following figure shows the general system layout.

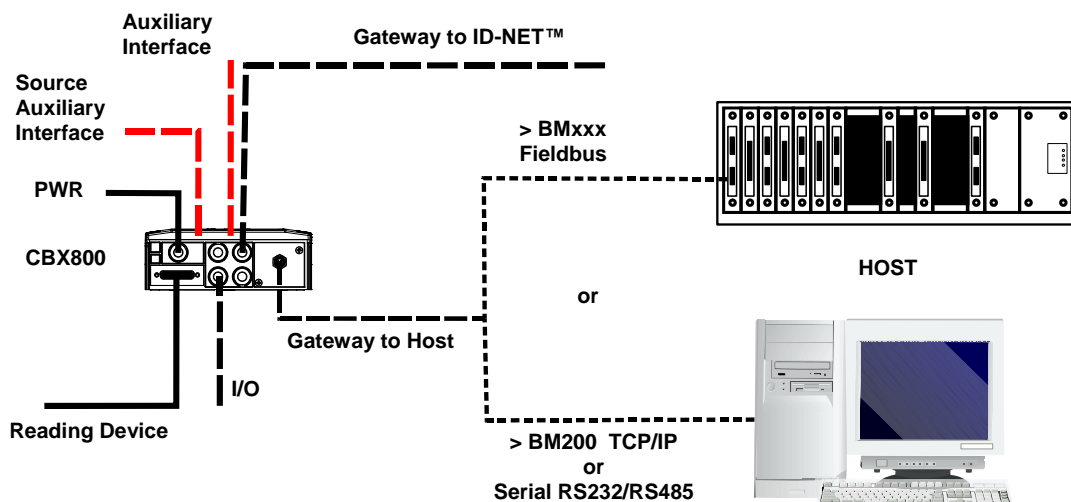


Figure 38 – General System Layout

The general system layout allows the CBX800 Gateway to connect any serial device (Hand-Held Reader, 6K, 8KA Scanner, Matrix-2000, etc.), collect its information and send it to a Host over a serial or TCP/IP or Fieldbus interface.

Generally the external system Host is connected to the CBX800 Host interface. The reading device connects to the 25-pin connector (Source). The reading device auxiliary interface signals are also available on the internal spring clamp connectors.

The ID-NET interface allows any serial device to be connected to a Full-Speed ID-NET™ compatible network.

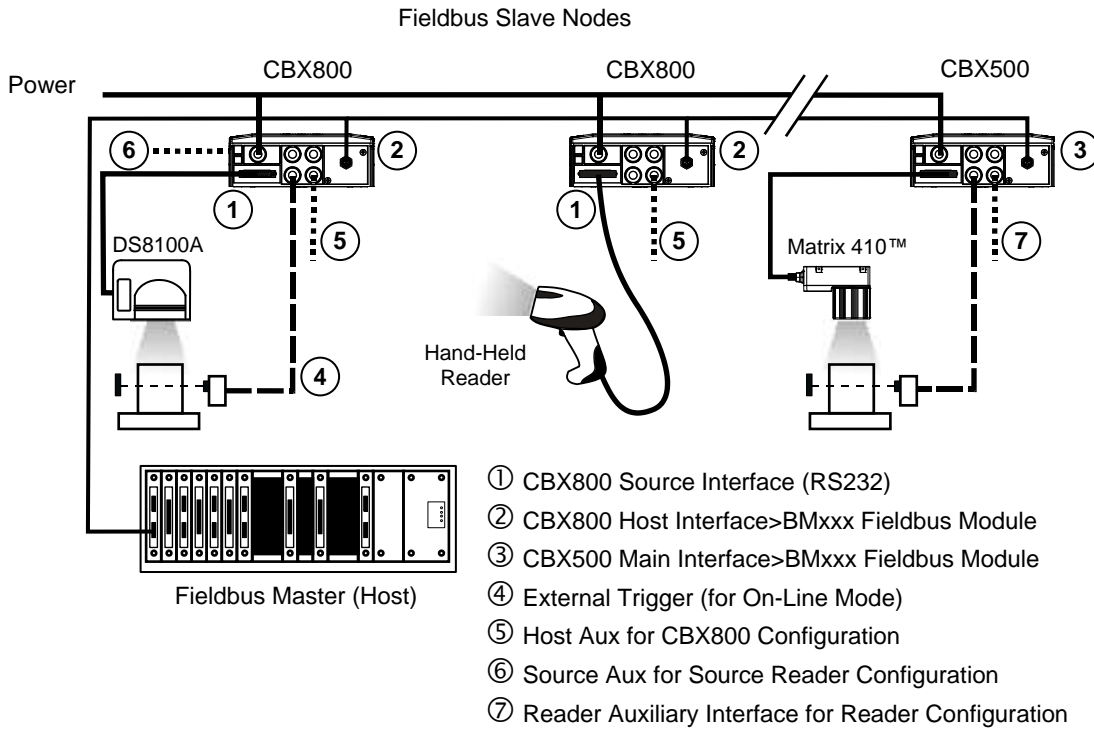
The dotted lines in the figure refer to optional hardware configurations.

A portable PC can be quickly connected to the CBX800 Auxiliary port through the internal 9-pin MUX/GWY connector for CBX800 configuration.

Likewise the portable PC can be quickly connected to the Source Auxiliary port through the internal 9-pin Source connector for reader configuration.

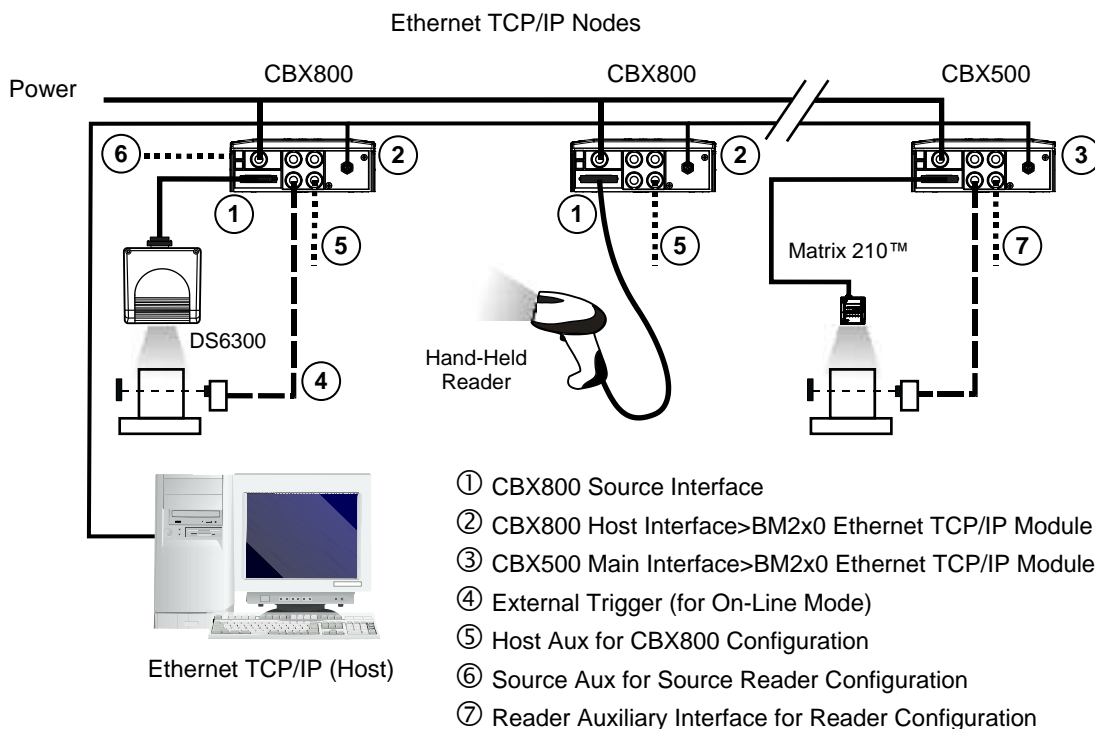
After making system cabling and switch settings, switch ON the CBX800 power switch (see Figure 4). The Power LED turns on (blue) when the power connection has the correct polarity. The Power LED turns on (red) in case of wrong polarity.

After CBX800 configuration and system functioning has been verified, close the CBX800 using the four cover screws.



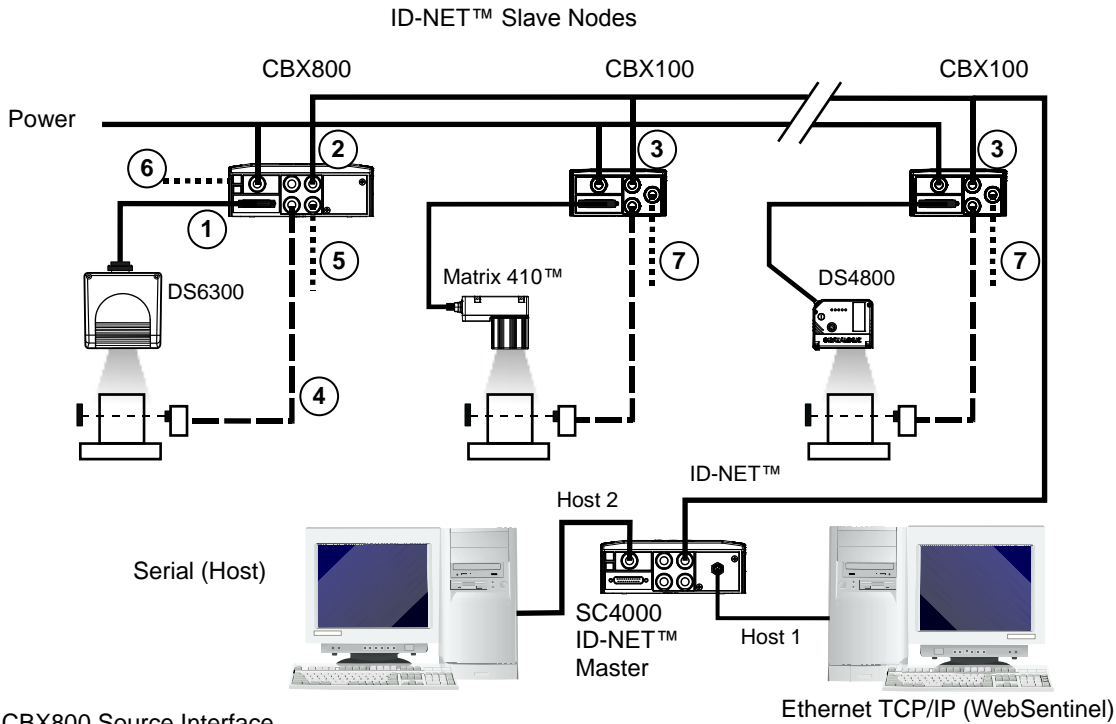
### Fieldbus Gateway

Layout	Fieldbus Gateway (ex: Profibus interface board = BM3x0)	Note
<b>CBX800 Parameters</b> sw package 003 and later		
Net Type Rotary Switch	<b>2</b>	
Address Rotary Switches	<b>X100 = 0, 1</b> <b>X10 = 0..9</b> <b>X1 = 0..9</b>	<b>Address Range= 00..126</b>
Topology Role	<b>Other</b>	
System Layout / Host Port Type	<b>Profibus</b>	
Communication Settings / Gateway / Status	<b>&lt;checked&gt;</b>	
Communication Settings / Gateway / Bus Communication / Node Address	<b>Aligned to the Fieldbus Master configuration</b>	
Communication Settings / Data Source Serial Port / Data Destination: Gateway	<b>&lt;checked&gt;</b>	
Communication Settings / Data Source Serial Port / Expected Termination String	<b>Aligned to the Data Source device configuration</b>	if Communication Settings /Data Source Serial Port / Send Data On = Termination String
Communication Settings / Data Source Serial Port / Line Parameters/ (all parameters)	<b>Aligned to the Data Source device configuration</b>	



### Ethernet TCP/IP Gateway


Layout	Ethernet TCP/IP Gateway (interface board = BM2x0)	Note
<b>CBX800 Parameters</b> sw package 003 and later		
Net Type Rotary Switch	<b>7</b>	
Topology Role	<b>Other</b>	
System Layout / Host Port Type	<b>Ethernet TCP/IP</b>	
Communication Settings / Gateway / Line Parameters/ (all parameters)	<b>Aligned to the LAN configuration</b>	
Communication Settings / Gateway / TCP/IP Services / User Socket #x / Status	<b>&lt;checked&gt;</b>	
Communication Settings / Data Source Serial Port / Data Destination: Gateway	<b>&lt;checked&gt;</b>	
Communication Settings / Data Source Serial Port / Expected Termination String	<b>Aligned to the Data Source device configuration</b>	if Communication Settings /Data Source Serial Port / Send Data On = Termination String
Communication Settings / Data Source Serial Port / Line Parameters/ (all parameters)	<b>Aligned to the Data Source device configuration</b>	

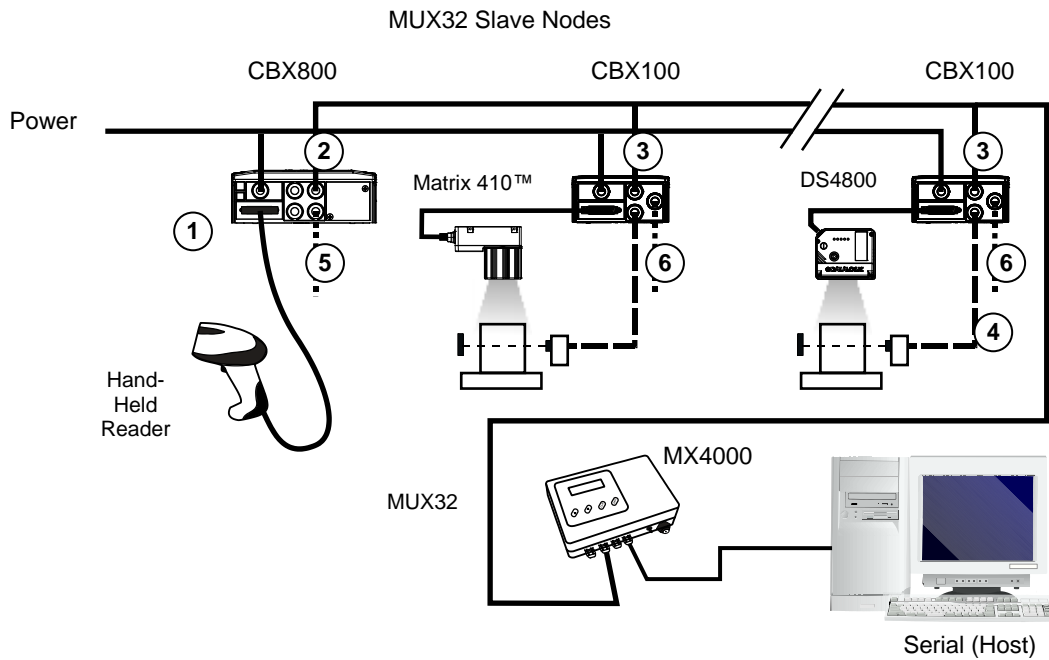


- ① CBX800 Source Interface
- ② CBX800 Full Speed ID-NET™ Interface
- ③ Reader ID-NET™ Interface
- ④ External Trigger (for On-Line Mode)
- ⑤ Host Aux for CBX800 Configuration
- ⑥ Source Aux for Source Reader Configuration
- ⑦ Reader Auxiliary Interface for Reader Configuration

### ID-NET™ Gateway

Layout	ID-Net Gateway	Note
<b>CBX800 Parameters</b> sw package 003 and later		
Net Type Rotary Switch	<b>9</b>	
Address Rotary Switches	<b>X100 = 0..9 (ID-Net Baud rate)</b> <b>X10 = 0..3</b> <b>X1 = 0..9</b>	<b>(X10 + X1) Address Range = 1..31</b>
Topology Role	<b>ID-NET Slave (Multidata)</b>	
System Layout / Network Baud Rate (bps)	<b>Aligned to the ID-Net Master baud rate</b>	<b>See par. Baudrate Selection</b>
System Layout / Host Port Type	<b>Serial</b>	
Communication Settings / Data Source Serial Port / Data Destination: ID-NET	<b>&lt;checked&gt;</b>	
Communication Settings / Data Source Serial Port / Expected Termination String	<b>Aligned to the Data Source device configuration</b>	if Communication Settings /Data Source Serial Port / Send Data On = Termination String
Communication Settings / Data Source Serial Port / Line Parameters/ (all parameters)	<b>Aligned to the Data Source device configuration</b>	

 **NOTE** For 6/8K family scanners having software version 6.80 or later, an alternative fixed speed (57600 baud) ID-NET™ layout can be made without the use of CBX800. See the ID-NET™ Application Note on the downloadable Genius mini-DVD file for details.  
For maximum ID-NET™ network performance use CBX800.



- ① CBX800 Source Interface
- ② CBX800 Host MUX32 Interface
- ③ Reader MUX32 Interface
- ④ External Trigger (for On-Line Mode)
- ⑤ Host Aux for CBX800 Configuration
- ⑥ Reader Auxiliary Interface for Reader Configuration

### MUX32 Gateway

Layout	MUX32 Gateway	Note
<b>CBX800 Parameters</b> sw package 003 and later		
Net Type Rotary Switch	<b>0</b>	
Topology Role	<b>Other</b>	
System Layout / Host Port Type	<b>Serial</b>	
System Layout / Host Port Serial Protocol	<b>MUX 32 slave</b>	
Communication Settings / Host Serial Port / Line Parameters / Baud Rate	<b>aligned to MUX32 network baud rate</b>	
Communication Settings / Host Serial Port / Line Parameters / MUX32 Protocol Address	<b>enabled on the MUX32 network</b>	
Communication Settings / Data Source Serial Port / Data Destination: Host Serial Port	<b>&lt;checked&gt;</b>	
Communication Settings / Data Source Serial Port / Expected Termination String	<b>Aligned to the Data Source device configuration</b>	if Communication Settings /Data Source Serial Port / Send Data On = Termination String
Communication Settings / Data Source Serial Port / Line Parameters/ (all parameters)	<b>Aligned to the Data Source device configuration</b>	



## TECHNICAL FEATURES

<b>ELECTRICAL FEATURES</b>	
Supply Voltage	10 to 30 Vdc*
Consumption	0.5 – 0.3 A
Limited Current Consumption CBX + reading device consumption (see related manual)	2.5 A Max
Inputs	Opto-isolated polarity insensitive 30 Vdc max; 12 mA max
Outputs	Opto-isolated polarity sensitive 30 Vdc max; 40 mA max continuous 130 mA max pulsed
<b>COMMUNICATION INTERFACES</b>	
Host Interface	RS232/RS485 up to 115.2 Kbit/s
Auxiliary	RS232 up to 115.2 Kbit/s
Data Source	RS232/RS485 up to 115.2 Kbit/s
ID-NET™	RS485 Half Duplex up to 1 Mbaud
Communication Protocols	Datalogic Application Driver (DAD Driver)
<b>USER INTERFACE</b>	
LED Indicators:	Power On/Polarity Error (blue/red), Trigger (yellow), IN2 (green) OUT1 (yellow), OUT2 (green), Ready (green), Host (yellow), Source (green), ID-NET (yellow), OUT3 (green)
Configuration Modes	Genius™ utility program Genius™ based Host Mode Programming
<b>PHYSICAL FEATURES</b>	
Mechanical Dimensions	193 x 180 x 71 mm (7.6 x 7.1 x 2.8 in.)
Weight	830 g. (29.28 oz.)
<b>ENVIRONMENTAL FEATURES</b>	
Operating Temperature	0° to 50 °C (+32° to 122 °F)
Storage Temperature	-20° to 70 °C (-4° to 158 °F)
Humidity max.	90% non condensing
Vibration Resistance EN 60068-2-6	14 mm @ 2 to 10 Hz; 1.5 mm @ 13 to 55 Hz; 2 g @ 70 to 200 Hz; 2 hours on each axis
Bump Resistance EN 60068-2-29	30 g; 6 ms; 5000 shocks on each axis
Protection Class EN 60529	IP65 **

The features given are typical at a 25 °C ambient temperature (if not otherwise indicated).

\* for further details about minimum/maximum supply voltage refer to the manual of the connected reading device, since the minimum supply voltage required may be >10.

\*\* when compression connectors and reading device are correctly connected.  
If Host Interface (Fieldbus) Modules are used, only correctly installed IP65 models guarantee IP protection.  
Protection is not guaranteed when Standard Fieldbus Modules are mounted.


## COMPLIANCE

---

### POWER SUPPLY

**This product is intended to be installed by Qualified Personnel only.**

This device is intended to be supplied by a UL Listed NEC Class 2 power source.

 <b>CAUTION</b>	<i>Total power consumption is given by adding the CBX800 power consumption to that of all the devices powered through the CBX800 (reading device, P.S., I/O). Refer to the manual of the connected devices for details about minimum/maximum supply voltage and power consumption.</i>
---	--

**Each CBX800 supports only 1 single reading device on the 25-pin connector + system accessories.**

### CE COMPLIANCE

CE marking states the compliance of the product with essential requirements listed in the applicable European directive. Since the directives and applicable standards are subject to continuous updates, and since Datalogic promptly adopts these updates, therefore the EU declaration of conformity is a living document. The EU declaration of conformity is available for competent authorities and customers through Datalogic commercial reference contacts. Since April 20<sup>th</sup>, 2016 the main European directives applicable to Datalogic products require inclusion of an adequate analysis and assessment of the risk(s). This evaluation was carried out in relation to the applicable points of the standards listed in the Declaration of Conformity. Datalogic products are mainly designed for integration purposes into more complex systems. For this reason it is under the responsibility of the system integrator to do a new risk assessment regarding the final installation.

**Warning:** This is a Class A product. In a domestic environment this product may cause radio interference in which case the user may be required to take adequate measures.

### FCC COMPLIANCE

Modifications or changes to this equipment without the expressed written approval of Datalogic could void the authority to use the equipment.

This device complies with PART 15 of the FCC Rules. Operation is subject to the following two conditions: (1) This device may not cause harmful interference, and (2) this device must accept any interference received, including interference which may cause undesired operation.

This equipment has been tested and found to comply with the limits for a Class A digital device, pursuant to part 15 of the FCC Rules. These limits are designed to provide reasonable protection against harmful interference when the equipment is operated in a commercial environment. This equipment generates, uses, and can radiate radio frequency energy and, if not installed and used in accordance with the instruction manual, may cause harmful interference to radio communications. Operation of this equipment in a residential area is likely to cause harmful interference in which case the user will be required to correct the interference at his own expense.

### EAC COMPLIANCE

Customs Union:

The CU Conformity certification has been achieved; this allows the Product to bear the Eurasian mark of conformity.